

mass integrated

global part distribution • product lifecycle partner
excess inventory management • value-ad service provider



Data sheet provided by Mass Integrated

massintegrated.com • displayalliance.com

Please call +1.978.465.6190
Email: sales@massintegrated.com



ISO 9001: 2008

Mass Integrated complies with all DMCA takedown notices. Please send a formal DMCA Takedown Notice to Mass Integrated Systems, Inc. • 18 Henry Graf Jr. Road, Unit 1 • Newburyport, MA 01950.



Product Specification

AU OPTRONICS CORPORATION

(V) Preliminary Specifications

() Final Specifications

Module	10.1" SD+ 16:10 TFT-LCD
Model Name	B101EW04 V0
Note ()	LED Backlight without driving circuit design

Customer	Date
<u>Normal</u>	<u>10/28/2010</u>
Checked & Approved by	Date
_____	_____
Note: This Specification is subject to change without notice.	

Approved by	Date
<u>CH Lin</u>	<u>10/28/2010</u>
Prepared by	
<u>Kevin Shen</u>	<u>10/28/2010</u>
NBBU Marketing Division / AU Optronics corporation	



Product Specification

AU OPTRONICS CORPORATION

Contents

1. Handling Precautions	3
2. General Description	3
2.1 General Specification.....	3
2.2 Optical Characteristics	3
3. Functional Block Diagram	3
The following diagram shows the functional block of the 10.1 inches wide Color TFT/LCD	
40 Pin (One ch/connector Module).....	3
4. Absolute Maximum Ratings	3
4.1 Absolute Ratings of TFT LCD Module	3
4.2 Absolute Ratings of Environment.....	3
5. Electrical characteristics.....	3
5.1 TFT LCD Module.....	3
5.2 Backlight Unit.....	3
6. Signal Characteristic	3
6.1 Pixel Format Image	3
6.2 The input data format.....	3
6.3 Integration Interface Requirement.....	3
6.4 Interface Timing	3
6.5 Power Sequence	3
6.5.1 Panel Power Sequence	3
7. Panel Reliability Test	3
7.1 Vibration Test	3
7.2 Shock Test.....	3
7.3 Reliability Test.....	3
8. Mechanical Characteristics	3
8.1 LCM Outline Dimension	3
9. Shipping and Package	3
9.1 Shipping Label Format.....	3
9.2 Carton Package	3
9.3 Shipping package of palletizing sequence.....	3
10. Appendix	3
10.1 EDID description	3



Product Specification

AU OPTRONICS CORPORATION

Record of Revision

Version and Date	Page	Old description	New Description	Remark
0.1 2010/10/28	All	First Edition for Customer		



1. Handling Precautions

- 1) Since front polarizer is easily damaged, pay attention not to scratch it.
- 2) Be sure to turn off power supply when inserting or disconnecting from input connector.
- 3) Wipe off water drop immediately. Long contact with water may cause discoloration or spots.
- 4) When the panel surface is soiled, wipe it with absorbent cotton or other soft cloth.
- 5) Since the panel is made of glass, it may break or crack if dropped or bumped on hard surface.
- 6) Since CMOS LSI is used in this module, take care of static electricity and insure human earth when handling.
- 7) Do not open nor modify the Module Assembly.
- 8) Do not press the reflector sheet at the back of the module to any directions.
- 9) At the insertion or removal of the Signal Interface Connector, be sure not to rotate nor tilt the Interface Connector of the TFT Module.
- 11) After installation of the TFT Module into an enclosure (Notebook PC Bezel, for example), do not twist nor bend the TFT Module even momentary. At designing the enclosure, it should be taken into consideration that no bending/twisting forces are applied to the TFT Module from outside. Otherwise the TFT Module may be damaged.
- 12) Small amount of materials having no flammability grade is used in the LCD module. The LCD module should be supplied by power complied with requirements of Limited Power Source (IEC60950 or UL1950), or be applied exemption.
- 13) Disconnecting power supply before handling LCD modules, it can prevent electric shock, DO NOT TOUCH the electrode parts, cables, connectors and LED circuit part of TFT module that a LED light bar build in as a light source of back light unit. It can prevent electrostatic breakdown.



Product Specification

AU OPTRONICS CORPORATION

2. General Description

B101EW03 V0 is a Color Active Matrix Liquid Crystal Display composed of a TFT LCD panel, a driver circuit, and LED backlight system. The screen format is intended to support 1280(H) x 800(V) screen and 262k colors (RGB 6-bits data driver) with LED backlight driving circuit. All input signals are LVDS interface compatible.

B101EW03 V0 is designed for a display unit of notebook style personal computer and industrial machine.

2.1 General Specification

The following items are characteristics summary on the table at 25 °C condition:

Items	Unit	Specifications			
Screen Diagonal	[mm]	255.85(10.07W")			
Active Area	[mm]	216.96(H) x 135.6(V)			
Pixels H x V		1280x3(RGB) x 800			
Pixel Pitch	[mm]	0.1695(H) x 0.1695(V)			
Pixel Arrangement		R.G.B. Vertical Stripe			
Display Mode		Normally Black			
White Luminance Note: I _{LED} is LED current	[cd/m ²]	400 typ, 320min			
Luminance Uniformity (5P)		1.25 max			
Contrast Ratio		600 min			
Response Time	[ms]	25 typ			
Nominal Input Voltage VDD	[Volt]	+3.3 typ.			
Power Consumption	[Watt]	Typ	Max		
		-	3.1W		
		@ Black pattern			
Weight	[Grams]	190g max.			
Physical Size	[mm]		L	W	T
		Max	229.96	149.6	5.56
		Typical	229.46	149.1	
		Min	228.96	148.6	3.39
Electrical Interface		1 channel LVDS			



Product Specification

AU OPTRONICS CORPORATION

Glass Thickness	[mm]	0.3
Surface Treatment		Glare
Support Color		262K colors (RGB 6-bit +FRC)
Temperature Range Operating Storage (Non-Operating)	[°C] [°C]	0 to +50 -20 to +60
RoHS Compliance		RoHS Compliance

2.2 Optical Characteristics

The optical characteristics are measured under stable conditions at 25°C (Room Temperature) :

Item	Symbol	Conditions	Min.	Typ.	Max.	Unit	Note
White Luminance ILED=18.5mA		5 points average	320	400	-	cd/m ²	1, 4, 5
Viewing Angle	θ_R	Horizontal (Right)	80	-	-	degree	4, 9
	θ_L	CR = 10 (Left)	80	-	-		
	ϕ_H	Vertical (Upper)	80	-	-		
	ϕ_L	CR = 10 (Lower)	80	-	-		
Luminance Uniformity	δ_{5P}	5 Points	-	-	1.25		1, 3, 4
Luminance Uniformity	δ_{13P}	13 Points	-	-	1.60		2, 3, 4
Contrast Ratio	CR		600	-	-		4, 6
Cross talk	%				4		4, 7
Response Time	T_r	Rising	-	-	-	msec	4, 8
	T_f	Falling	-	-	-		
	T_{RT}	Rising + Falling	-	25	-		
Color / Chromaticity Coordinates	Red	Rx	0.542	0.582	0.622	CIE 1931	4
		Ry	0.303	0.343	0.383		
	Green	Gx	0.294	0.334	0.374		
		Gy	0.540	0.580	0.620		
	Blue	Bx	0.107	0.147	0.187		
		By	0.089	0.129	0.169		
	White	Wx	0.273	0.313	0.353		
		Wy	0.289	0.329	0.369		
	NTSC	%		-	45		

Note 1: 5 points position (Ref: Active area)

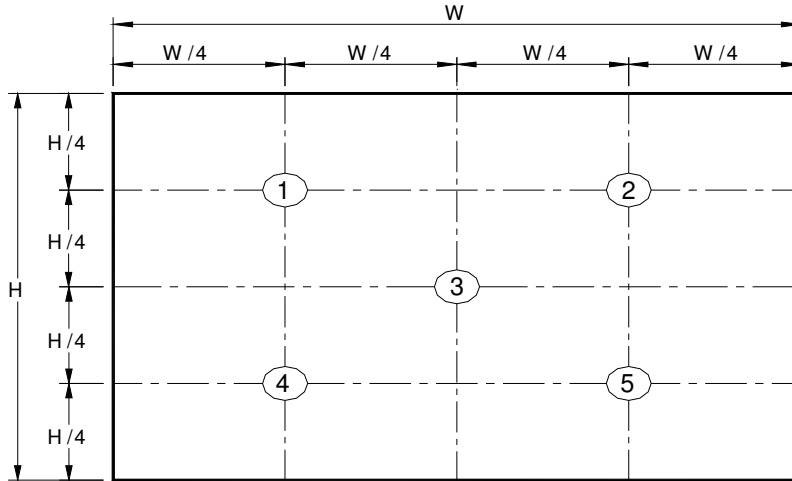

Note 2: 13 points position (Ref: Active area)

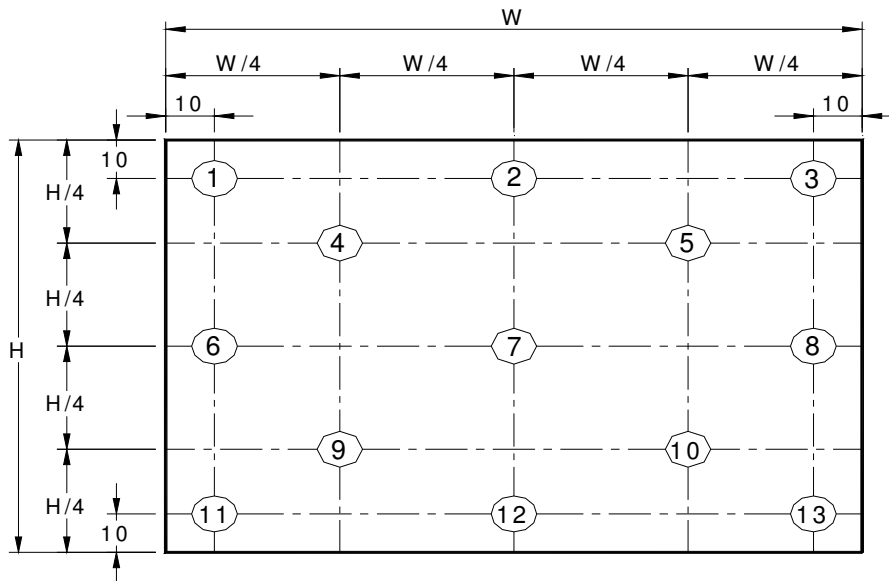

Note 3: The luminance uniformity of 5 or 13 points is defined by dividing the maximum luminance values by the minimum test point luminance

$$\delta_{W5} = \frac{\text{Maximum Brightness of five points}}{\text{Minimum Brightness of five points}}$$

$$\delta_{W13} = \frac{\text{Maximum Brightness of thirteen points}}{\text{Minimum Brightness of thirteen points}}$$

Note 4: Measurement method

The LCD module should be stabilized at given temperature for 30 minutes to avoid abrupt temperature change during measuring. In order to stabilize the luminance, the measurement should be executed after lighting Backlight for 30 minutes in a stable, windless and dark room, and it should be measured in the center of screen.

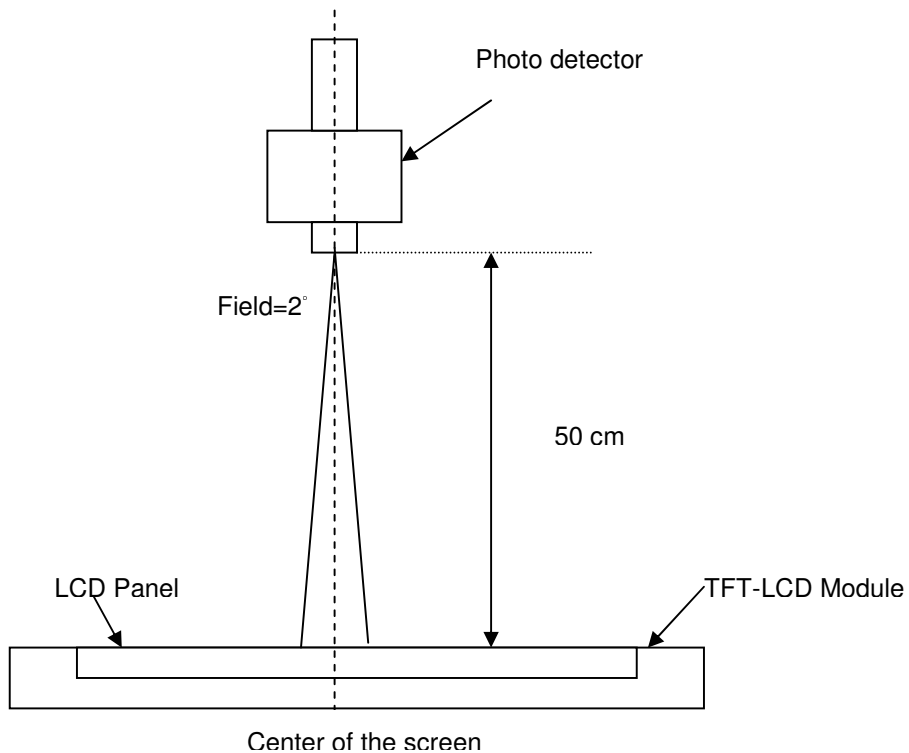

Note 5 : Definition of Average Luminance of White (Y_L):

Measure the luminance of gray level 63 at 5 points , $Y_L = [L (1)+ L (2)+ L (3)+ L (4)+ L (5)] / 5$

$L (x)$ is corresponding to the luminance of the point X at Figure in Note (1).

Note 6 : Definition of contrast ratio:

Contrast ratio is calculated with the following formula.

$$\text{Contrast ratio (CR)} = \frac{\text{Brightness on the "White" state}}{\text{Brightness on the "Black" state}}$$

Note 7 : Definition of Cross Talk (CT)

$$CT = |Y_B - Y_A| / Y_A \times 100 (\%)$$

Where

Y_A = Luminance of measured location without gray level 0 pattern (cd/m²)

Y_B = Luminance of measured location with gray level 0 pattern (cd/m²)

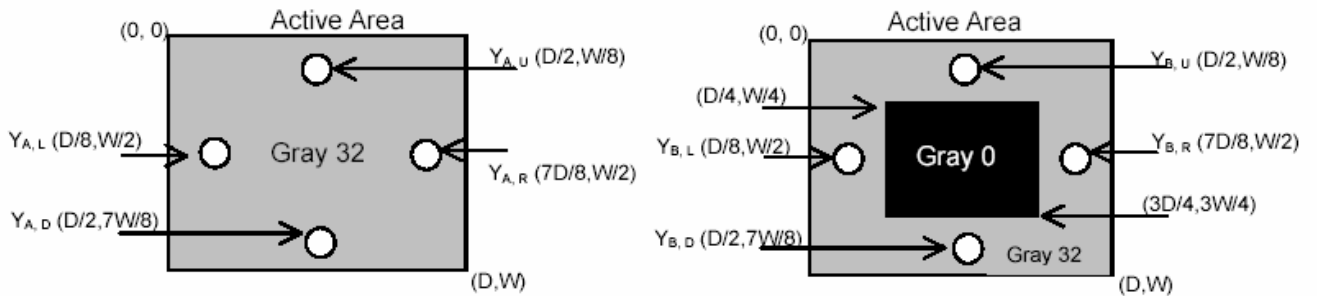

Note 8: Definition of response time:

The output signals of BM-7 or equivalent are measured when the input signals are changed from “Black” to “White” (falling time) and from “White” to “Black” (rising time), respectively. The response time interval between the 10% and 90% of amplitudes. Refer to figure as below.

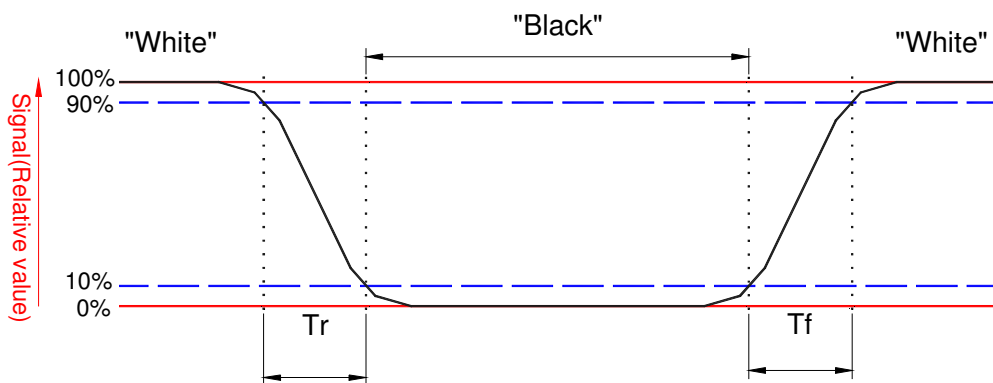

Note 9. Definition of viewing angle

Viewing angle is the measurement of contrast ratio ≥ 10 , at the screen center, over a 180° horizontal and 180° vertical range (off-normal viewing angles). The 180° viewing angle range is broken down as follows; 90° (θ) horizontal left and right and 90° (Φ) vertical, high (up) and low (down). The measurement direction is typically perpendicular to the display surface with the screen rotated about its center to develop the desired measurement viewing angle.

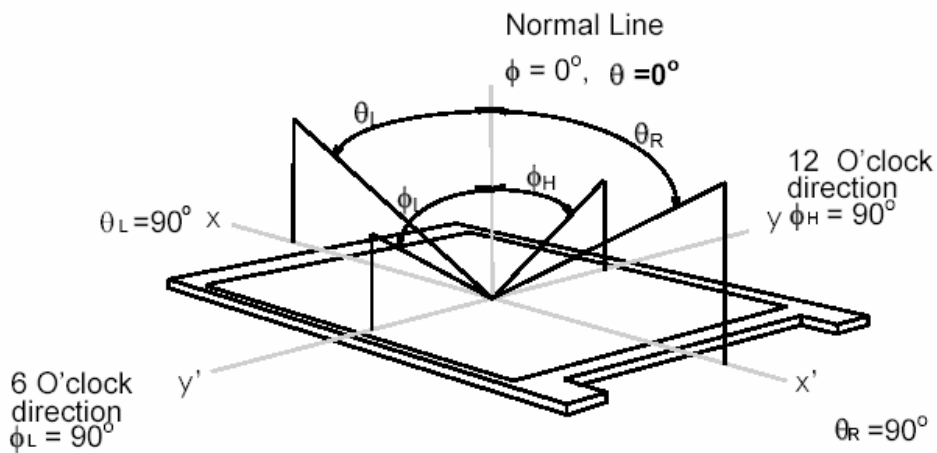



Product Specification

AU OPTRONICS CORPORATION

3. Functional Block Diagram

The following diagram shows the functional block of the 10.1 inches wide Color TFT/LCD 40 Pin (One ch/connector Module).

TBD

4. Absolute Maximum Ratings

An absolute maximum rating of the module is as following:

4.1 Absolute Ratings of TFT LCD Module

Item	Symbol	Min	Max	Unit	Conditions
Logic/LCD Drive Voltage	Vin	-0.3	+4.0	[Volt]	Note 1,2

4.2 Absolute Ratings of Environment

Item	Symbol	Min	Max	Unit	Conditions
Operating Temperature	TOP	0	+50	[°C]	Note 4
Operation Humidity	HOP	5	95	[%RH]	Note 4
Storage Temperature	TST	-20	+60	[°C]	Note 4
Storage Humidity	HST	5	95	[%RH]	Note 4

Note 1: At Ta (25°C)

Note 2: Permanent damage to the device may occur if exceed maximum values

Note 3: LED specification refer to section 5.2

Note 4: For quality performance, please refer to AUO IIS (Incoming Inspection Standard).

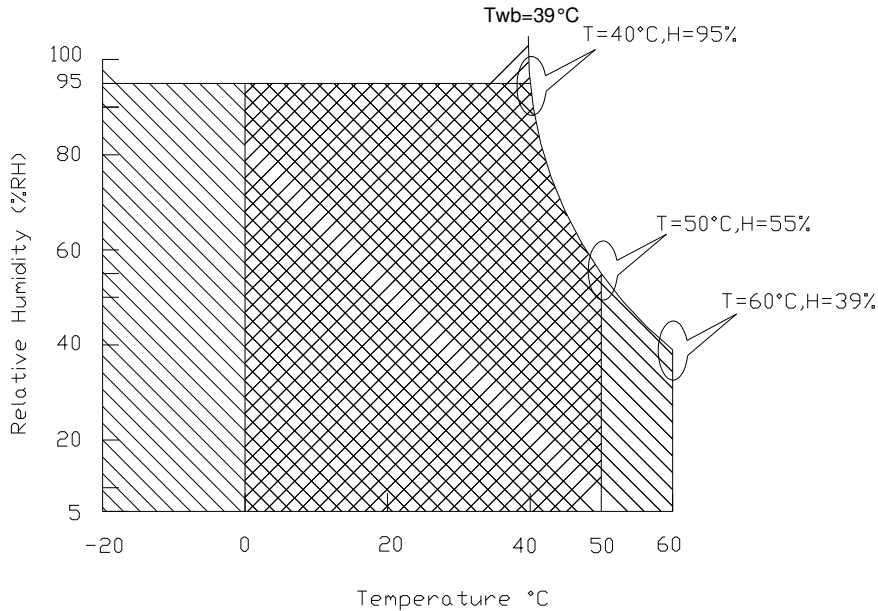

Operating Range 

Storage Range

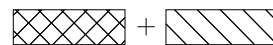

5. Electrical characteristics

5.1 TFT LCD Module

5.1.1 Power Specification

Input power specifications are as follows;

Symble	Parameter	Min	Typ	Max	Unit	Note
VDD	Logic/LCD Drive Voltage	3.0	3.3	3.6	[Volt]	
PDD	VDD Power	-	-	1.0	[Watt]	Note 1/2
IDD	IDD Current	-	257.6	303.03	[mA]	Note 1/2
IRush	Inrush Current	-	-	1500	[mA]	Note 3
VDDrp	Allowable Logic/LCD Drive Ripple Voltage	-	-	100	[mV] p-p	

Note 1 : Maximum Measurement Condition : Black Pattern

Note 2 : Typical Measurement Condition: Mosaic Pattern

Note 3 : Measure Condition

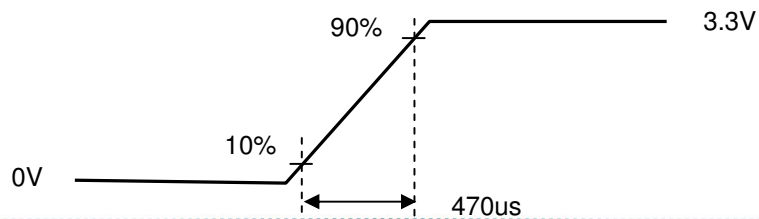
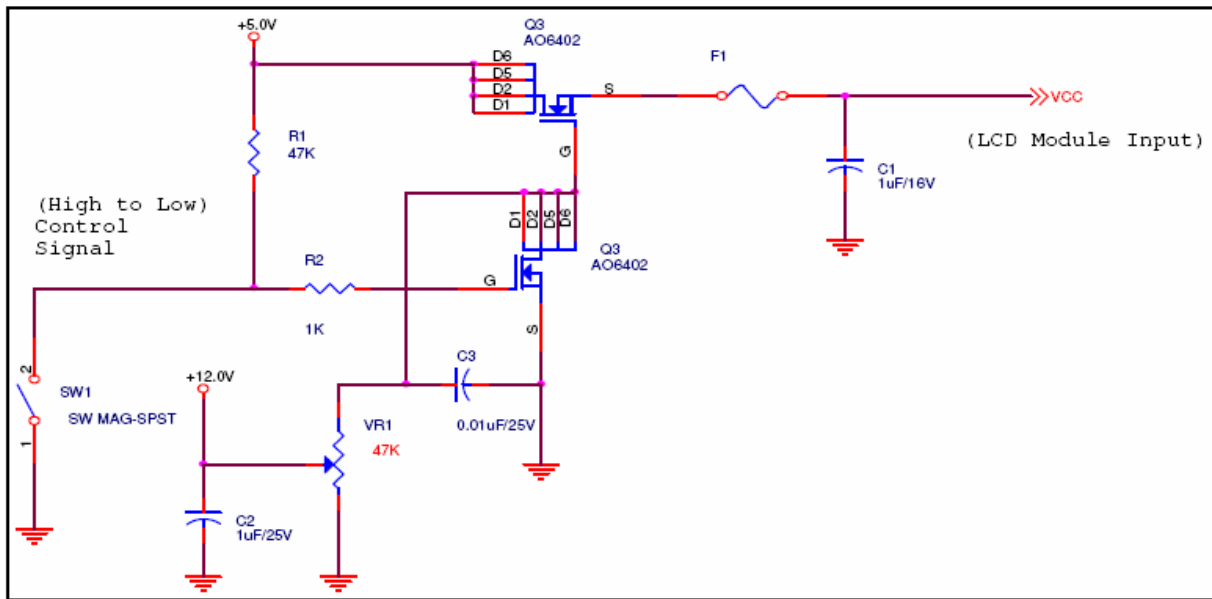

5.1.2 Signal Electrical Characteristics

Input signals shall be low or High-impedance state when VDD is off.

It is recommended to refer the specifications of SN75LVDS82DGG (Texas Instruments) in detail.

Signal electrical characteristics are as follows;

Parameter	Condition	Min	Max	Unit
V_{th}	Differential Input High Threshold ($V_{cm}=+1.2V$)		100	[mV]
V_{tl}	Differential Input Low Threshold ($V_{cm}=+1.2V$)	-100	-	[mV]
V_{ID}	Differential Input Voltage	100	600	[mV]
V_{cm}	Differential Input Common Mode Voltage	1.125	1.375	[V]

Note: LVDS Signal Waveform

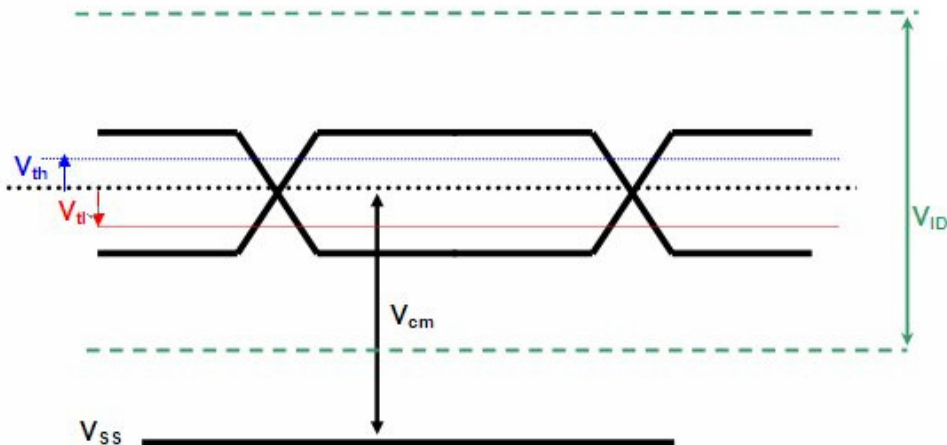



Product Specification

AU OPTRONICS CORPORATION

5.2 Backlight Unit

5.2.1 LED characteristics

Parameter	Symbol	Min	Typ	Max	Units	Condition
Backlight Power Consumption	PLED	-	-	2.1	[Watt]	(Ta=25°C), Note 1 Type I, V_{in} =12V
LED Life-Time	N/A	12,000	-	-	Hour	(Ta=25°C), Note 2 I _F =18.5 mA

Note 1: Calculator value for reference $P_{LED} = VF$ (Normal Distribution) * I_F (Normal Distribution) / Efficiency

Note 2: The LED life-time define as the estimated time to 50% degradation of initial luminous

Note 3: This panel will support lower duty ratio at PWM conditional frequency. The PWM frequency constrain between 100 Hz to 300 Hz and a same typical 200Hz. The duty ratio support from 5% to 100%.

5.2.2 Backlight input signal characteristics

Parameter	Symbol	Min	Typ	Max	Units	Remark
LED Power Supply	VLED	6.0	12.0	21.0	[Volt]	Type I, Note 1
		4.5	5	5.5	[Volt]	Type II, Note 1
LED Enable Input High Level	VLED_EN	2.5	-	5.5	[Volt]	PWM Frequency <5K Hz PWM Frequency ≥ 500 Hz
LED Enable Input Low Level		-	-	0.8	[Volt]	
PWM Logic Input High Level	VPWM_EN	2.5	-	5.5	[Volt]	
PWM Logic Input Low Level		-	-	0.8	[Volt]	
PWM Input Frequency	FPWM	100	-	1K	Hz	
PWM Duty Ratio	Duty	1	--	100	%	
PWM Duty Ratio	Duty	15	--	100	%	

Note 1: **Type I** and **II** is an independent of design parameter. It should be separated from system design.

6. Signal Characteristic

6.1 Pixel Format Image

Following figure shows the relationship of the input signals and LCD pixel format.

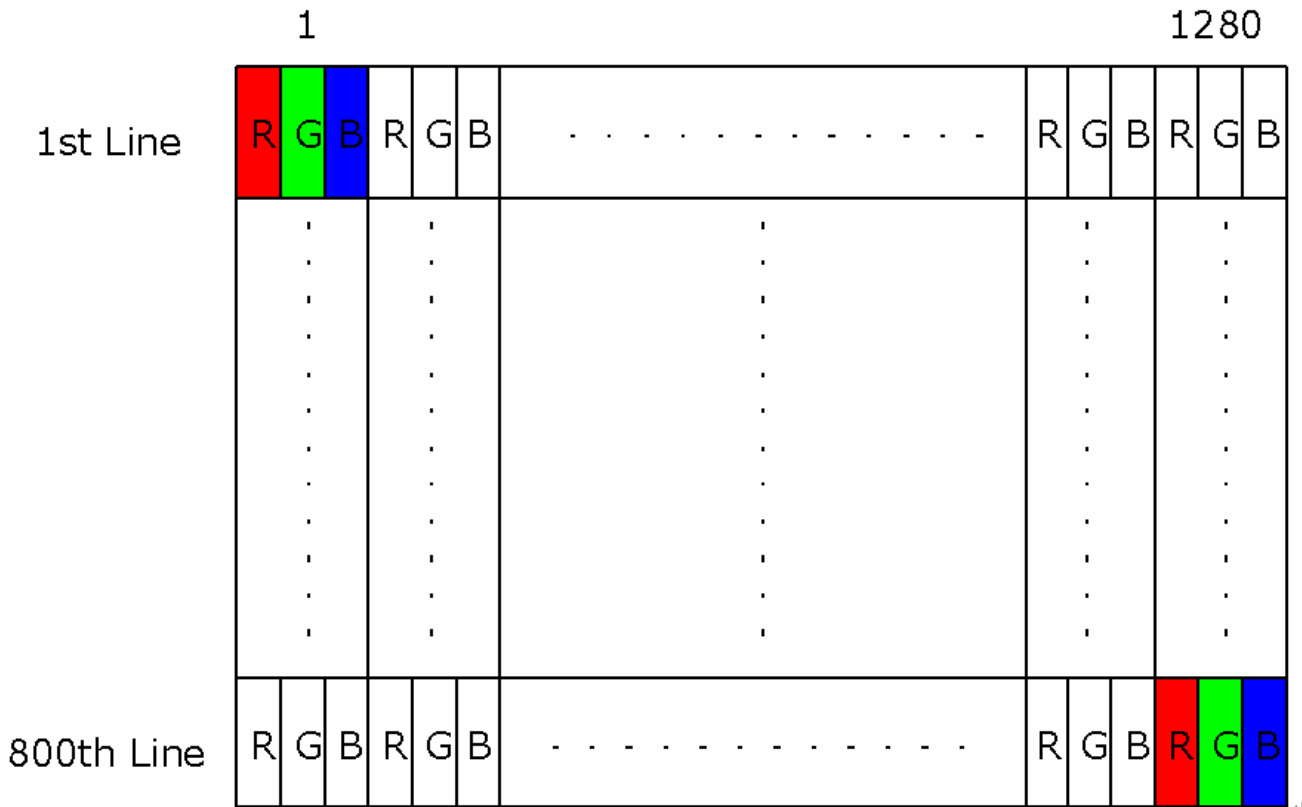

6.2 The input data format

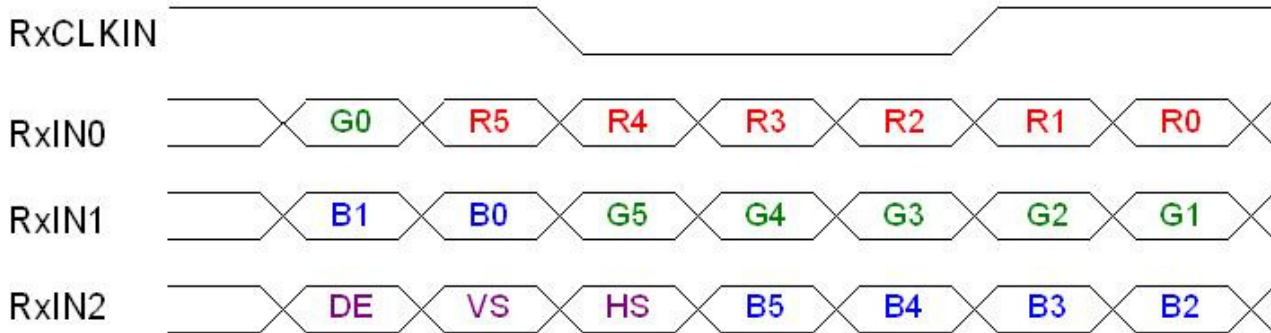

Signal Name	Description	
R5 R4 R3 R2 R1 R0	Red Data 5 (MSB) Red Data 4 Red Data 3 Red Data 2 Red Data 1 Red Data 0 (LSB)	Red-pixel Data Each red pixel's brightness data consists of these 6 bits pixel data.
G5 G4 G3 G2 G1 G0	Green Data 5 (MSB) Green Data 4 Green Data 3 Green Data 2 Green Data 1 Green Data 0 (LSB)	Green-pixel Data Each green pixel's brightness data consists of these 6 bits pixel data.
B5 B4 B3 B2 B1 B0	Blue Data 5 (MSB) Blue Data 4 Blue Data 3 Blue Data 2 Blue Data 1 Blue Data 0 (LSB)	Blue-pixel Data Each blue pixel's brightness data consists of these 6 bits pixel data.
RxCLKIN	Data Clock	The typical frequency is 54.2MHZ. The signal is used to strobe the pixel data and DE signals. All pixel data shall be valid at the falling edge when the DE signal is high.
DE	Display Timing	This signal is strobed at the falling edge of RxCLKIN. When the signal is high, the pixel data shall be valid to be displayed.
VS	Vertical Sync	The signal is synchronized to RxCLKIN .
HS	Horizontal Sync	The signal is synchronized to RxCLKIN .

Note: Output signals from any system shall be low or High-impedance state when VDD is off.

6.3 Integration Interface Requirement

6.3.1 Connector Description

Physical interface is described as for the connector on module.

These connectors are capable of accommodating the following signals and will be following components.

Connector Name / Designation	For Signal Connector
Manufacturer	Tyco
Type / Part Number	Tyco 2069716-3 (I-PEX 20455-040E-12 compatible)
Mating Housing/Part Number	IPEX 20453-040T-11 or compatible

6.3.2 Pin Assignment

LVDS is a differential signal technology for LCD interface and high speed data transfer device.

Pin	Signal	Description
1	NC	No connect
2	Vdd	Logic supply, +3.3V
3	Vdd	Logic supply, +3.3V
4	NC	No connect, Aging for AUO
5	Sclk	I2C series input clock
6	Sdat	I2C data I/O
7	NC	No connect
8	Rin0-	Receiver signal of LVDS CH0(-)
9	Rin0+	Receiver signal of LVDS CH0(+)
10	GND	Ground
11	Rin1-	Receiver signal of LVDS CH1(-)
12	Rin1+	Receiver signal of LVDS CH1(+)
13	GND	Ground
14	Rin2-	Receiver signal of LVDS CH2(-)
15	Rin2+	Receiver signal of LVDS CH2(+)
16	GND	Ground
17	Rclk-	Receiver signal of LVDS Clock (-)
18	Rclk+	Receiver signal of LVDS Clock (+)
19	GND	Ground
20	Rin3-	Receiver signal of LVDS CH3(-)
21	Rin3+	Receiver signal of LVDS CH3(+)
22	GND	Ground



Product Specification

AU OPTRONICS CORPORATION

23	NC	No connect
24	NC	No connect
25	GND	Ground
26	NC	No connect
27	Color(EN)	Color Enhancement enable (1=on, 0=off)
28	CABC(EN)	Content BL control enable (1=on, 0=off)
29	LED_PWM(I)	PWM signal to TCON
30	LED_PWM(O)	PWM signal from TCON
31	NC	No connect
32	LED_Cat_1	LED cathode
33	LED_Cat_2	LED cathode
34	LED_Cat_3	LED cathode
35	LED_Cat_4	LED cathode
36	LED_Cat_5	LED cathode
37	LED_Cat_6	LED cathode
38	NC	No connect
39	LED_Anode	LED Anode
40	LED_Anode	LED Anode

LVDS is a differential signal technology for LCD interface and high speed data transfer device.

6.4 Interface Timing

6.4.1 Timing Characteristics

Basically, interface timings should match the 1280 x 720 /60Hz manufacturing guide line timing.

Parameter	Symbol	Min.	Typ.	Max.	Unit	
Frame Rate	-	-	60		Hz	
Clock frequency	$1/T_{\text{Clock}}$	-	68.9	80	MHz	
Vertical Section	Period	T_V	808	816	1023	T_{Line}
	Active	T_{VD}	800	800	800	
	Blanking	T_{VB}	8	16	223	
Horizontal Section	Period	T_H	1310	1408	2047	T_{Clock}
	Active	T_{HD}	1280	1280	1280	
	Blanking	T_{HB}	30	128	767	

Note : DE mode only

6.4.2 Timing diagram

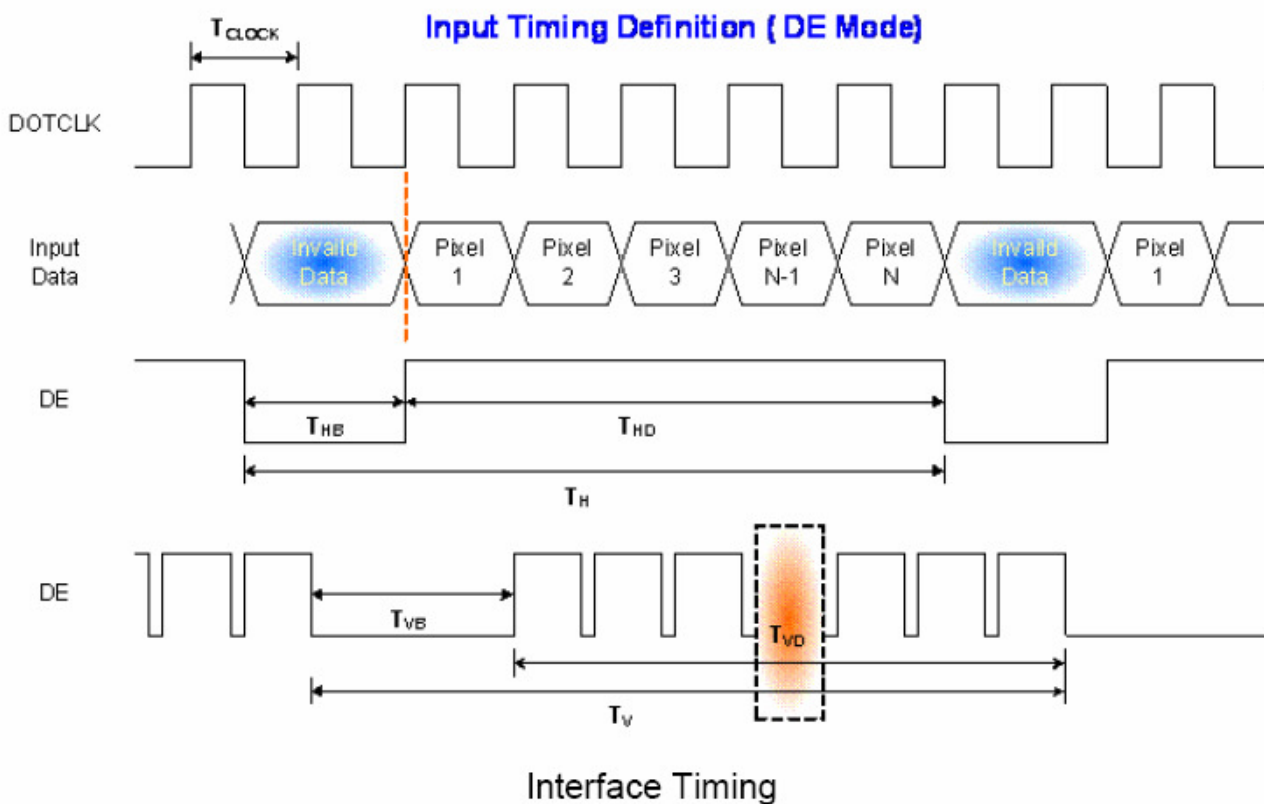

6.5 Power Sequence

6.5.1 Panel Power Sequence

VDD power and LED on/off sequence is as follows. Interface signals are also shown in the chart. Signals from any system shall be Hi-Z state or low level when VDD is off.

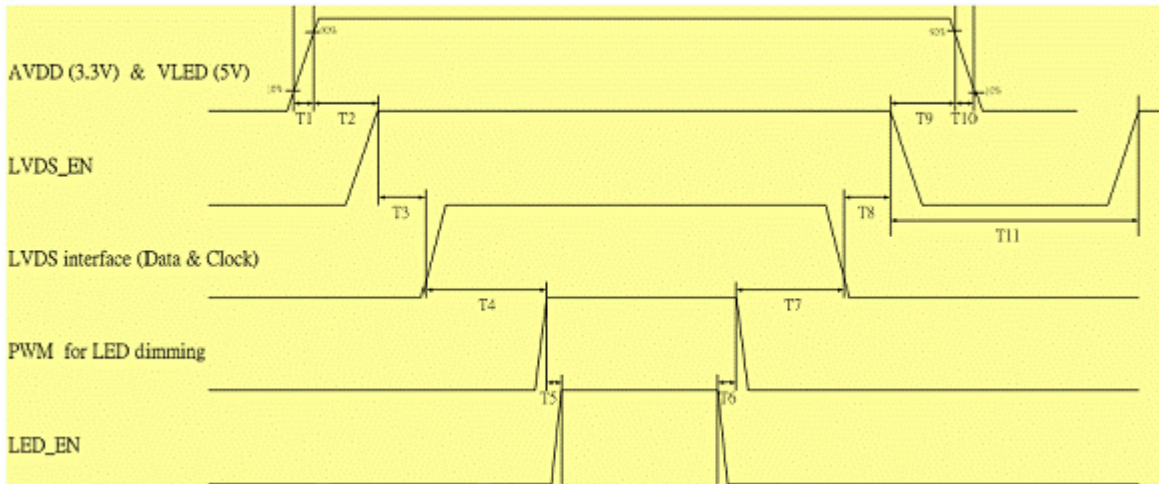

Power Sequence Timing				
Parameter	Value			Condition
	Min.(ms)	Typ.(ms)	Max.(ms)	
T1	0.5	-	10	
T2	0	-	50	
T3	200	-	-	
T4	0.5	-	10	
T5	10	-	-	
T6	10	-	-	
T7	0	-	-	
T8	10	-	200	VLED=6~21V(Type I)
	10	-	-	VLED=5V(type II)
T9	0	-	10	
T10	200	-	-	
T11	0.5	-	50	
T12	0	-	10	
T13	400	-	-	

Note 1 : If $T4 < 200\text{ms}$, the display garbage may occur. We suggest $T4 > 200\text{ms}$ to avoid the display garbage.

Note 2 : If $T1$ or $T2 < 0.5\text{ms}$, the inrush current may cause the damage of fuse. If the $T1$ or $T12 < 0.5\text{ms}$, the inrush current I^2t is under typical melt of fuse Spec., there's no above mentioned problem.

7. Panel Reliability Test

7.1 Vibration Test

Test Spec:

- Test method: Non-Operation
- Acceleration: 1.5 G
- Frequency: 10 - 500Hz Random
- Sweep: 30 Minutes each Axis (X, Y, Z)

7.2 Shock Test

Test Spec:

- Test method: Non-Operation
- Acceleration: 220 G , Half sine wave
- Active time: 2 ms
- Pulse: X,Y,Z .one time for each side

7.3 Reliability Test

Items	Required Condition	Note
Temperature Humidity Bias	Ta= 40°C , 90%RH, 300h	
High Temperature Operation	Ta= 50°C , Dry, 300h	
Low Temperature Operation	Ta= 0°C , 300h	
High Temperature Storage	Ta= 60°C , 35%RH, 300h	
Low Temperature Storage	Ta= -20°C , 50%RH, 250h	
Thermal Shock Test	Ta=-20°C to 60°C , Duration at 30 min, 100 cycles	
ESD	Contact : ±8 KV Air : ±15 KV	Note 1

Note1: According to EN 61000-4-2 , ESD class B: Some performance degradation allowed. No data lost
 . Self-recoverable. No hardware failures.

Remark: MTBF (Excluding the LED): 30,000 hours with a confidence level 90%



Product Specification

AU OPTRONICS CORPORATION

8. Mechanical Characteristics

8.1 LCM Outline Dimension

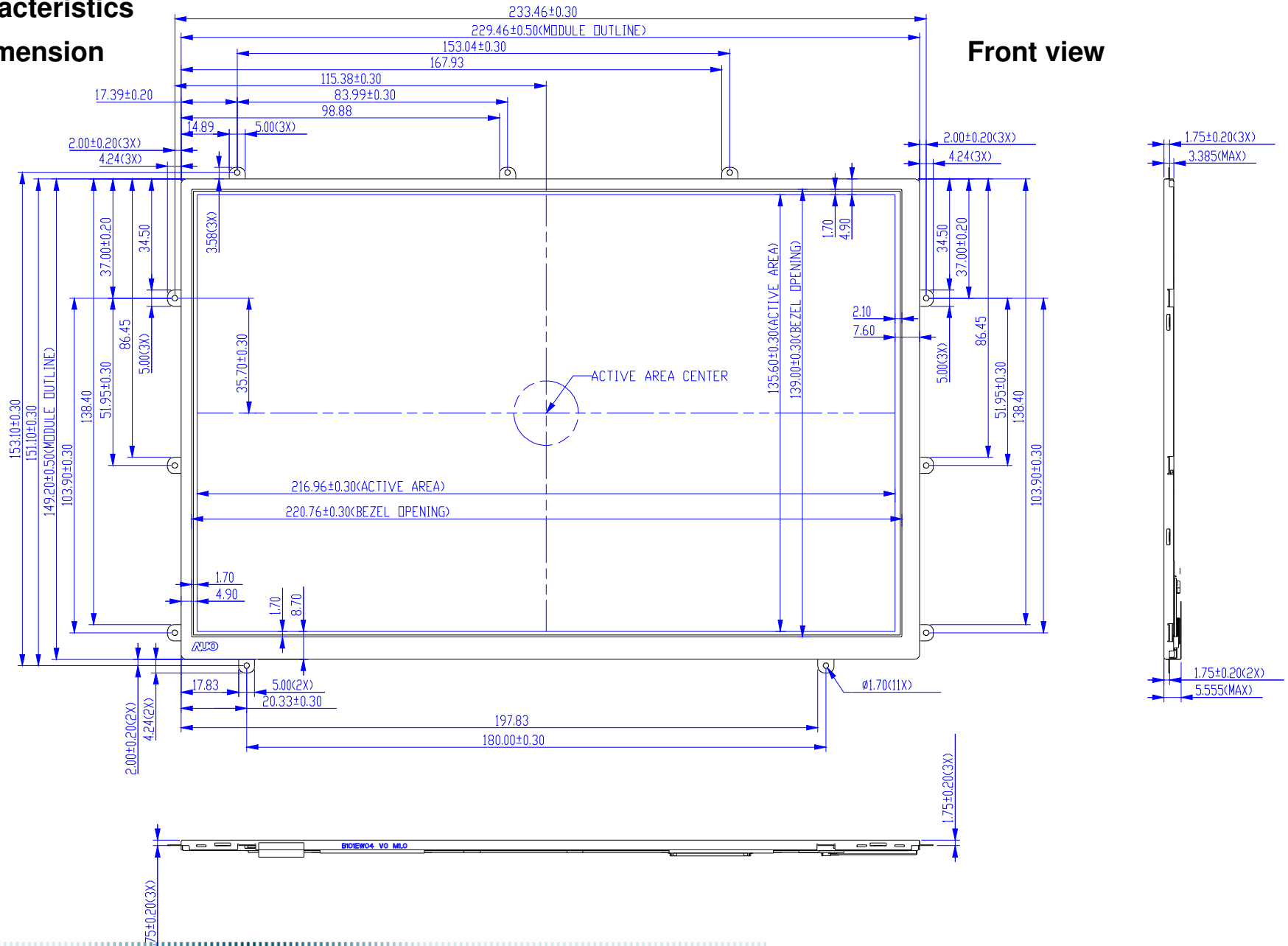

Back View

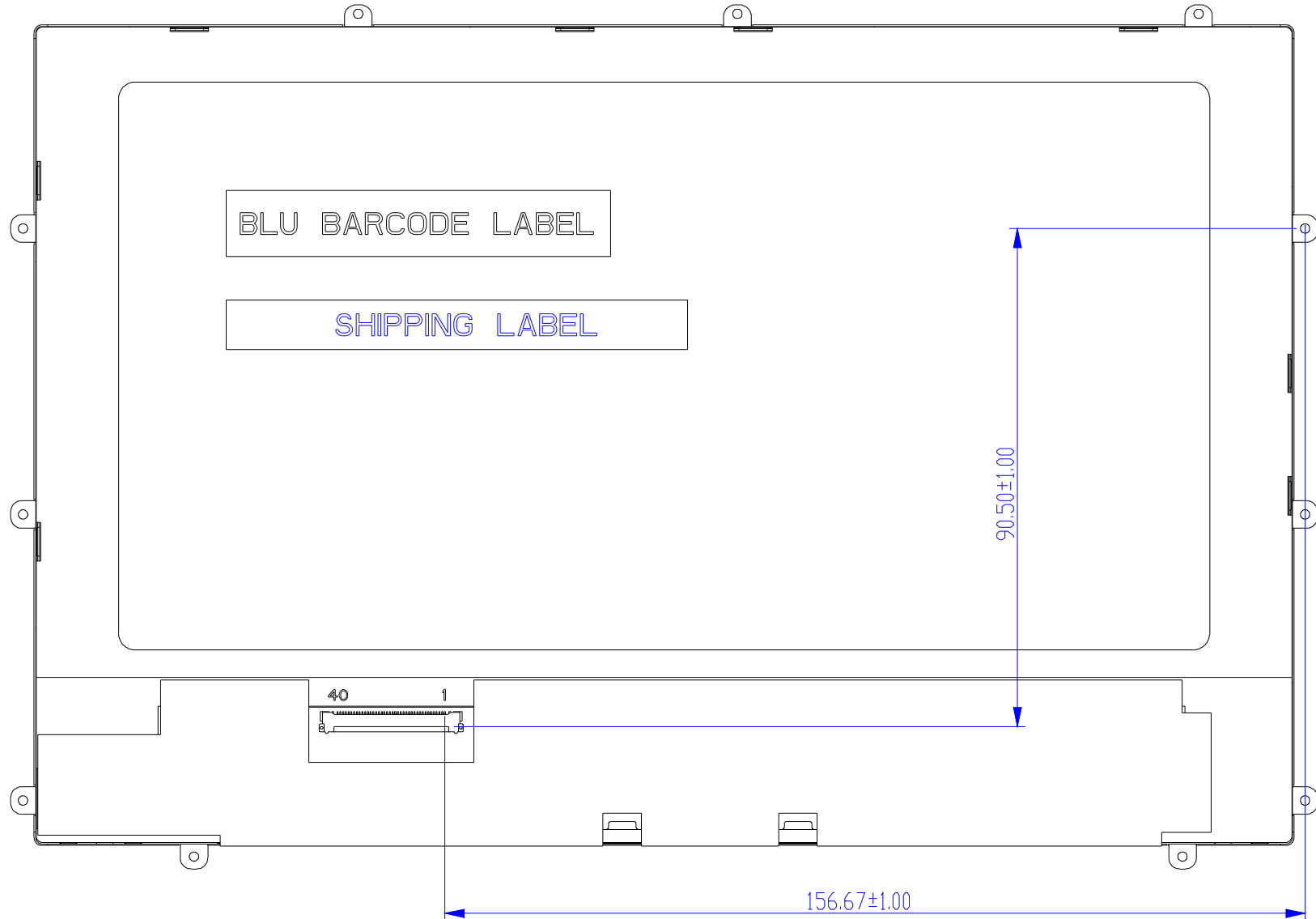

9. Shipping and Package

9.1 Shipping Label Format

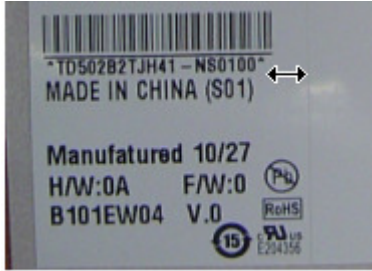

Label location

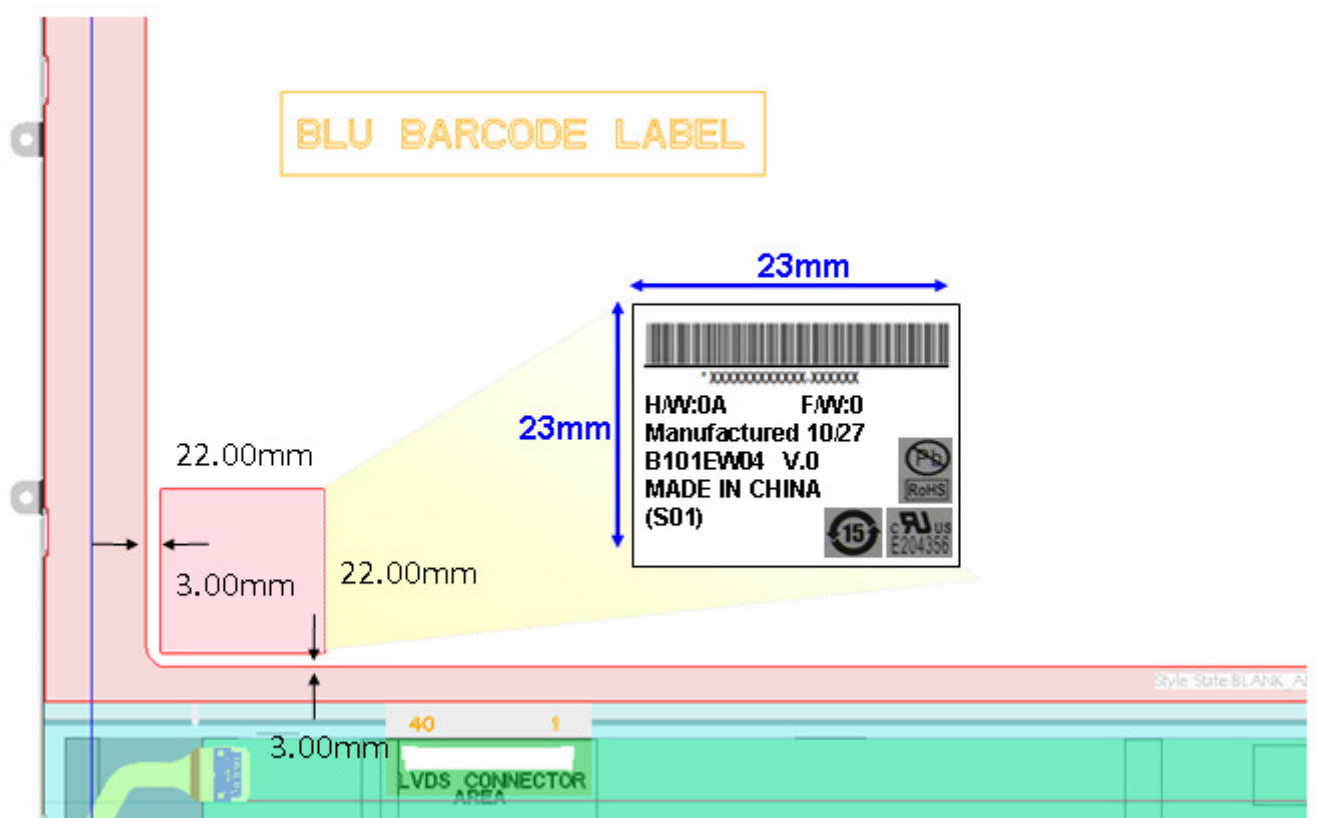

9.2 Carton Package

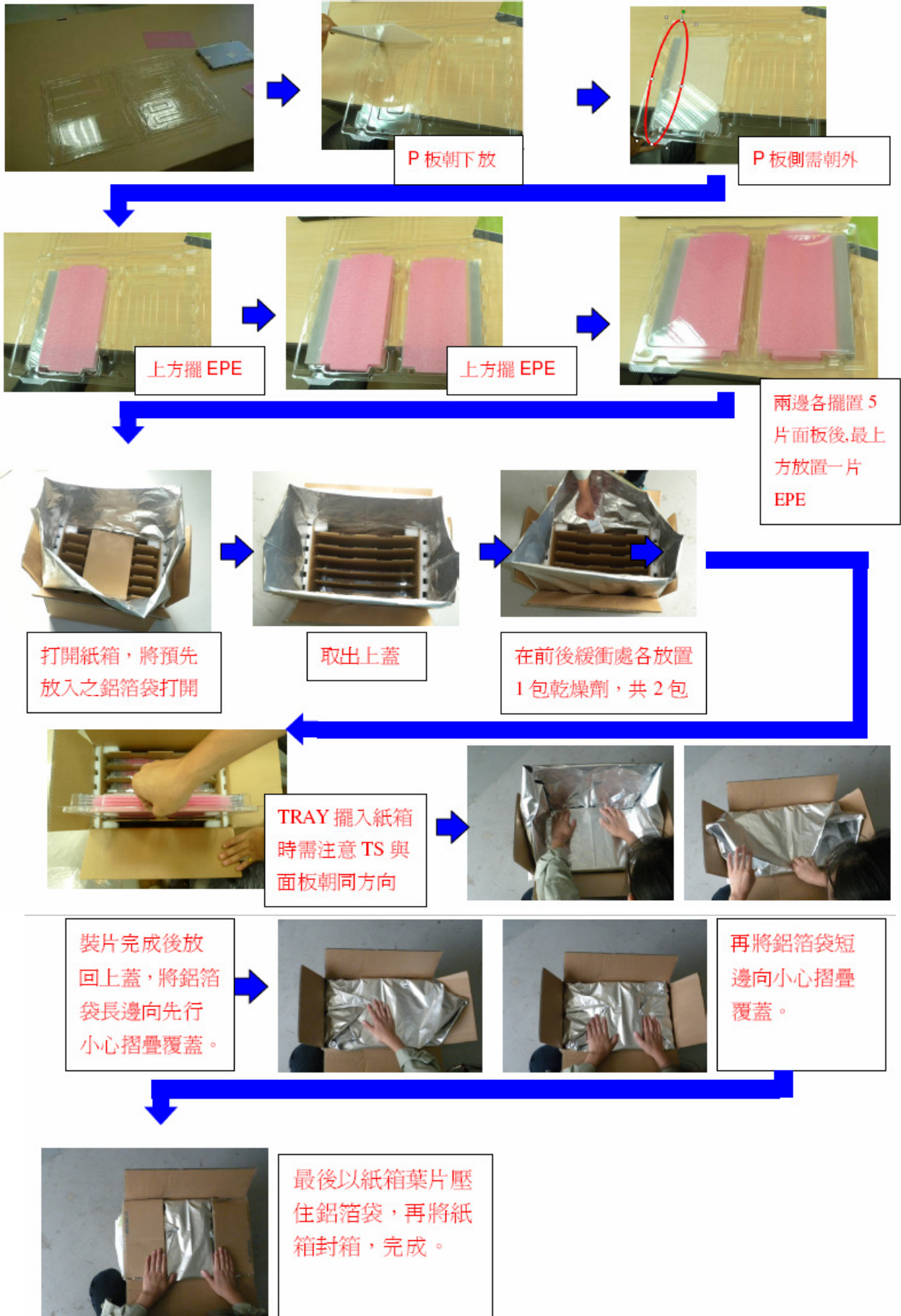

9.3 Shipping package of palletizing sequence

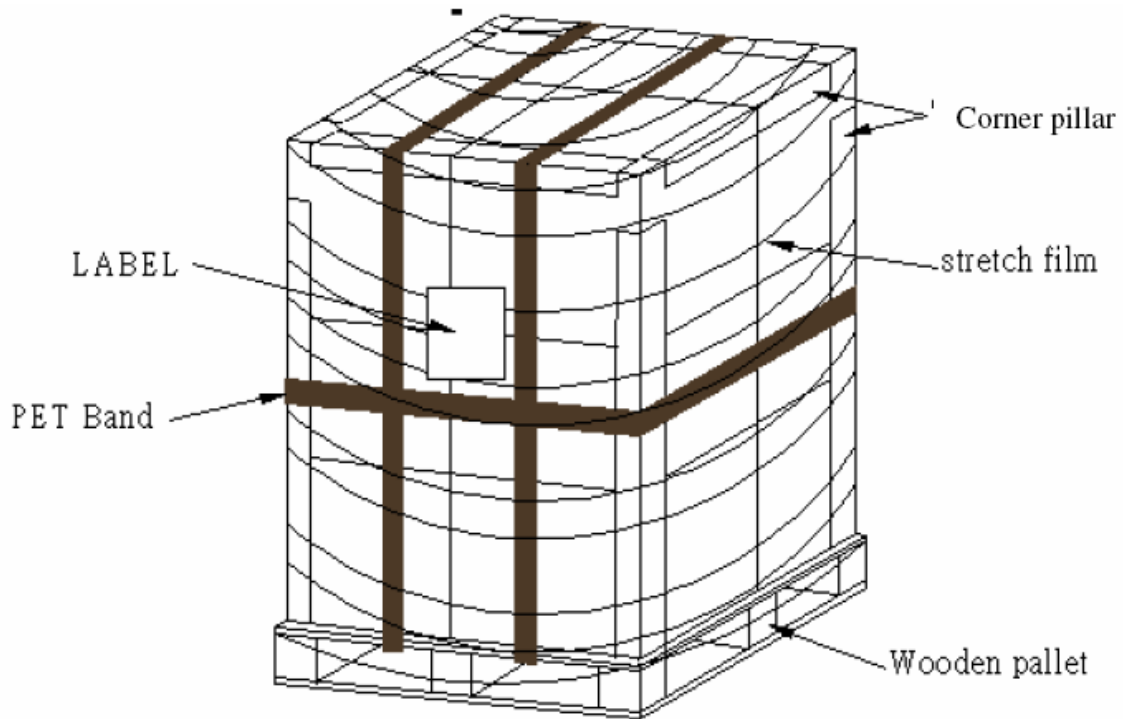

單層 pallet 打棧示意圖

One pallet illustration



10. Appendix

10.1 EDID description

Address	FUNCTION	Value	Value	Value	Note
HEX		HEX	BIN	DEC	
00	Header	00	00000000	0	
01		FF	11111111	255	
02		FF	11111111	255	
03		FF	11111111	255	
04		FF	11111111	255	
05		FF	11111111	255	
06		FF	11111111	255	
07		00	00000000	0	
08	EISA Manuf. Code LSB	06	00000110	6	
09	Compressed ASCII	AF	10101111	175	
0A	Product Code	D4	11010100	212	
0B	hex, LSB first	40	01000000	64	
0C	32-bit ser #	00	00000000	0	
0D		00	00000000	0	
0E		00	00000000	0	
0F		00	00000000	0	
10	Week of manufacture	01	00000001	1	
11	Year of manufacture	14	00010100	20	
12	EDID Structure Ver.	01	00000001	1	
13	EDID revision #	03	00000011	3	
14	Video input def. (digital I/P, non-TMDS, CRGB)	80	10000000	128	
15	Max H image size (rounded to cm)	17	00010111	23	
16	Max V image size (rounded to cm)	0F	00001111	15	
17	Display Gamma (=gamma*100)-100	78	01111000	120	
18	Feature support (no DPMS, Active OFF, RGB, tmg Blk#1)	0A	00001010	10	
19	Red/green low bits (Lower 2:2:2:2 bits)	61	01100001	97	
1A	Blue/white low bits (Lower 2:2:2:2 bits)	75	01110101	117	
1B	Red x (Upper 8 bits)	95	10010101	149	
1C	Red y/ highER 8 bits	55	01010101	85	
1D	Green x	54	01010100	84	
1E	Green y	8C	10001100	140	
1F	Blue x	27	00100111	39	
20	Blue y	22	00100010	34	
21	White x	50	01010000	80	
22	White y	54	01010100	84	
23	Established timing 1	00	00000000	0	
24	Established timing 2	00	00000000	0	
25	Established timing 3	00	00000000	0	



Product Specification

AU OPTRONICS CORPORATION

26	Standard timing #1	01	00000001	1	
27		01	00000001	1	
28	Standard timing #2	01	00000001	1	
29		01	00000001	1	
2A	Standard timing #3	01	00000001	1	
2B		01	00000001	1	
2C	Standard timing #4	01	00000001	1	
2D		01	00000001	1	
2E	Standard timing #5	01	00000001	1	
2F		01	00000001	1	
30	Standard timing #6	01	00000001	1	
31		01	00000001	1	
32	Standard timing #7	01	00000001	1	
33		01	00000001	1	
34	Standard timing #8	01	00000001	1	
35		01	00000001	1	
36	Pixel Clock/10000 LSB	12	00010010	18	
37	Pixel Clock/10000 USB	1B	00011011	27	
38	Horz active Lower 8bits	00	00000000	0	
39	Horz blanking Lower 8bits	94	10010100	148	
3A	HorzAct:HorzBlnk Upper 4:4 bits	50	01010000	80	
3B	Vertical Active Lower 8bits	20	00100000	32	
3C	Vertical Blanking Lower 8bits	08	00001000	8	
3D	Vert Act : Vertical Blanking (upper 4:4 bit)	30	00110000	48	
3E	HorzSync. Offset	8	00001000	8	
3F	HorzSync.Width	A	00001010	10	
40	VertSync.Offset : VertSync.Width	31	00110001	49	
41	Horz&Vert Sync Offset/Width Upper 2bits	00	00000000	0	
42	Horizontal Image Size Lower 8bits	E5	11100101	229	
43	Vertical Image Size Lower 8bits	95	10010101	149	
44	Horizontal & Vertical Image Size (upper 4:4 bits)	00	00000000	0	
45	Horizontal Border (zero for internal LCD)	00	00000000	0	
46	Vertical Border (zero for internal LCD)	00	00000000	0	
47	Signal (non-intr, norm, no stero, sep sync, neg pol)	18	00011000	24	
48	Detailed timing/monitor	00	00000000	0	
49	descriptor #2	00	00000000	0	
4A		00	00000000	0	
4B		0F	00001111	15	
4C		00	00000000	0	
4D		00	00000000	0	
4E		00	00000000	0	
4F		00	00000000	0	



Product Specification

AU OPTRONICS CORPORATION

50		00	00000000	0	
51		00	00000000	0	
52		00	00000000	0	
53		00	00000000	0	
54		00	00000000	0	
55		00	00000000	0	
56		00	00000000	0	
57		00	00000000	0	
58		00	00000000	0	
59		20	00100000	32	
5A	Detailed timing/monitor	00	00000000	0	
5B	descriptor #3	00	00000000	0	
5C		00	00000000	0	
5D		FE	11111110	254	
5E		00	00000000	0	
5F	Manufacture	41	01000001	65	A
60	Manufacture	55	01010101	85	U
61	Manufacture	4F	01001111	79	O
62		0A	00001010	10	
63		20	00100000	32	
64		20	00100000	32	
65		20	00100000	32	
66		20	00100000	32	
67		20	00100000	32	
68		20	00100000	32	
69		20	00100000	32	
6A		20	00100000	32	
6B		20	00100000	32	
6C	Detailed timing/monitor	00	00000000	0	
6D	descriptor #4	00	00000000	0	
6E		00	00000000	0	
6F		FE	11111110	254	
70		00	00000000	0	
71	Manufacture P/N	42	01000010	66	B
72	Manufacture P/N	31	00110001	49	1
73	Manufacture P/N	30	00110000	48	0
74	Manufacture P/N	31	00110001	49	1
75	Manufacture P/N	45	01000101	69	E
76	Manufacture P/N	57	01010111	87	W
77	Manufacture P/N	30	00110000	48	0
78	Manufacture P/N	34	00110100	52	4
79	Manufacture P/N	20	00100000	32	
7A	Manufacture P/N	56	01010110	86	V



Product Specification

AU OPTRONICS CORPORATION

7B	Manufacture P/N	30	00110000	48	0
7C		20	00100000	32	
7D		0A	00001010	10	
7E	Extension Flag	00	00000000	0	
7F	Checksum	43	01000011	67	
SUM				5888	