

LCD MODULE SPECIFICATION FOR CUSTOMER'S APPROVAL

CUSTOMER : Standard

MODULE TYPE : 16032A-201

APPROVED BY: (FOR CUSTOMER USE ONLY)

Approved By	Checked By	Prepared By	MT File No	Date Issued

CONTENTS

ITEM	PAGE
Surface	1
Content	2
Specification Of LCM	3
Lcd Module Drawing	4
General Specification	5
Absolute Maximum Rating	5
Electrical Characteristics	6
Optical Characteristics	6
Mechanical Specification	7
Interface Pin Assignment	8,9,10
Block Diagram	11
Timing Characteristics	12,13
Display Dada Ram Addressing	14
Display Commands	15
Command Description	16,17,18,19
Initialization Procedure	20
Reliability Test	21
Appearance Check	21
Handling Precautions	22
Lcd Product Quality Standard	23
Interface circuit and driving programme	24-28
Revision History	29

Specification For
Liquid Crystal Display Module
MODEL NO. : 16032A-201

View Direction	<input checked="" type="checkbox"/> 6 O'clock		<input type="checkbox"/> 12 O'clock		
LCD Type	<input type="checkbox"/> FSTN Positive		<input type="checkbox"/> FSTN Negative		
	<input checked="" type="checkbox"/> STN Gray	<input type="checkbox"/> STN Yellow Green	<input type="checkbox"/> STN Blue		
Rear Polarizer	<input type="checkbox"/> Reflective	<input checked="" type="checkbox"/> Transflective		<input type="checkbox"/> Transmissive	
Backlight Type	<input checked="" type="checkbox"/> LED	<input type="checkbox"/> Internal Power	<input type="checkbox"/> EL		<input checked="" type="checkbox"/> 5V input
		<input type="checkbox"/> External Power	<input type="checkbox"/> CCFL		<input type="checkbox"/> 24V input
Backlight Color	<input type="checkbox"/> White	<input type="checkbox"/> Amber	<input type="checkbox"/> Blue Green	<input checked="" type="checkbox"/> Yellow	<input type="checkbox"/> Other
Temperature Range	<input checked="" type="checkbox"/> Normal		<input type="checkbox"/> Wide		<input type="checkbox"/> Super Wide
EL Driver IC	<input type="checkbox"/> Build-in		<input checked="" type="checkbox"/> Not Build-in		
DC-to-DC	<input checked="" type="checkbox"/> With		<input type="checkbox"/> Without		

To Be Very Careful !

The LCD driver ICs are made by CMOS process, which are very easy to be damaged by static charge, make sure the user is grounded when handling the LCM.

LCM Module Drawing

QiuTian,ShiJia **16032A-201** 160X32 GRAPHIC
1/32DUTY, 1/5BI AS

1.0 DIMENSIONAL DRAWING

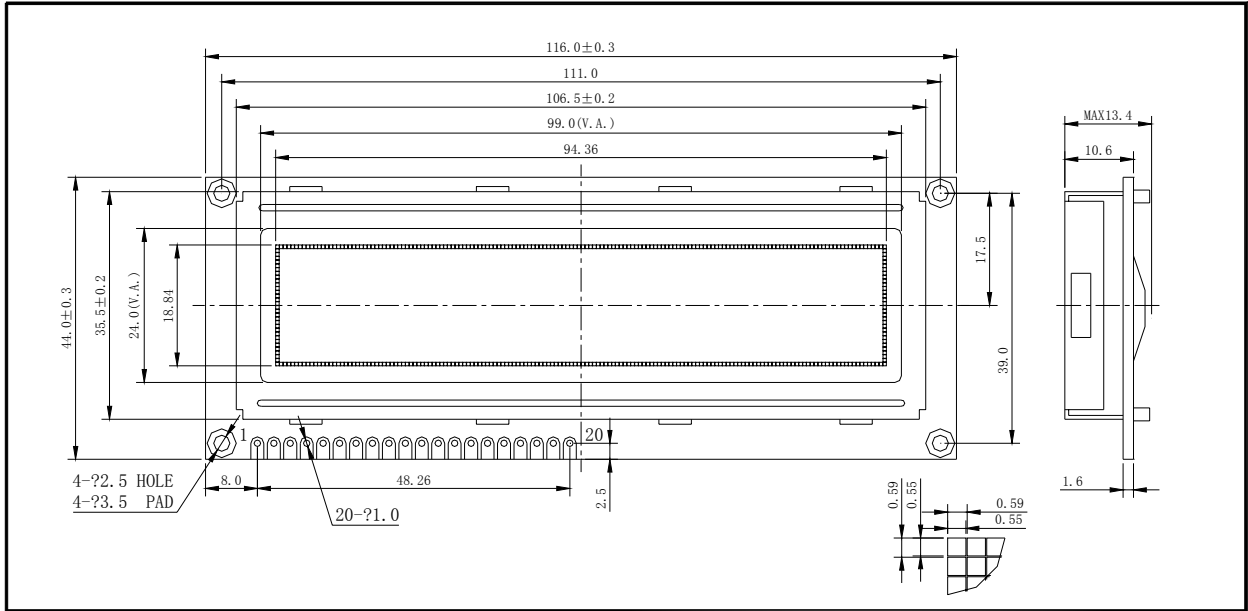

2.0 BLOCK DIAGRAM & POWER SUPPLY

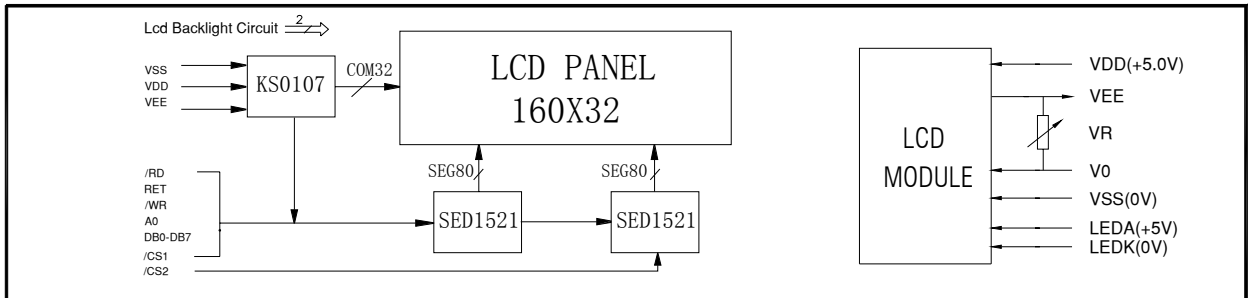

3.0 MECHANICAL SPECIFICATIONS & FEATURE

Item	Nominal Dimensions(mm)	FEATURE	
		LCD Type	STN
Module Size (W*H*T)	116.0x44.0x13.4	LCD Colour	Gray
View Area (W*H)	99.0x24.0	View Angle	6 O'clock
Character Font	160x32	Display Type	Positive Type
Dot Pitch (W*H)	0.59x0.59	Rear polarizer	Transflective
Dot Size (W*H)	0.55x0.55	Operating Temperature	0° C ~ 50° C
---	---	Storage Temperature	-20° C ~ 70° C
---	---	Backlight	LED(Yellow)

4.0 ELECTRICAL CHARACTERISTICS

Item	Symbol	Test Condition	Min.	Typ.	Max.	Unit
Operating Voltage	Vdd	Ta=25° C	---	5.0	---	V
Operating Voltage for LCD	Vlcd	Ta=25° C	---	6.5	---	V
Supply Current	Idd	Ta=25° C, Vdd=5V	---	4.0	---	mA
Supply Current for Backlight	If	Ta=25° C, Vf=4.2V	---	160	200	mA

5.0 INTERFACE PIN CONNECTIONS

Pin No	Symbol	Level	Description
1	A0	H/L	Register selection (H:Data register, L:Instruction register)
2	CS2	L	Chip select signal for Half-right screen
3	CS1	L	Chip select signal for Half-left screen
4	/RD(E)	L (H/H → L)	/RD for 80 serial, E for 68 serial
5	/WR(R/W)	L (H/L)	/WR for 80 serial, R/W for 68 serial
6	VDD		Logic supply voltage (+5V)
7	VSS		GND
8-15	DB0-DB7	H/L	3-state I/O Data Bus
16	RET		Reset signal The rise of the signal is for active and keep RET='h'
17	V0		Power supply for LCD
18	VEE	0	Nogtave voltage output
19	LEDA		Power supply for LED backlight(+5v)
20	LEDK		Power supply for LED backlight(0v)

General Specification

Item	Content
Display Resolution	160(W)×32(H)
Dimensional Outline(mm)	116.0(W)×44.0(H)×13.4max(D)
Display mode	Transfltive Type/Positive
Circuit	Common-Driver IC, Segment-driver IC with build-in SRAM
Interface	A0,CS2,CS1,E,R/W,VDD,VSS,DB0-DB7,RET,V0,VEE,LEDA,LEDK

Absolute Maximum Rating

(1) Electrical Absolute Ratings

Item	Symbol	Min.	Max.	Unit	Note
Power Supply for Logic	$V_{DD}-V_{SS}$	0	5.5	Volt	
Power Supply for LCD	$V_{DD}-V_O$	0	5.0	Volt	
Input Voltage	V_I	0	V_{DD}	Volt	
Static Electricity	-	0	5.5	Volt	Note 1
Supply Current for LED Backlight	I_{LED}	-	-	-	

Note 1 : Operator should be grounded during handling LCM.

(2) Environmental Absolute Maximum Ratings

Item	Normal Temperature				Wide Temperature			
	Operating		Storage		Operating		Storage	
	Min,	. Max,	Min,	. Max,	Min,	. Max,	Min,	. Max,
Ambient Temperature	0°C	+50°C	-20°C	+70°C	-20°C	+70°C	-30°C	+80°C
Humidity(without condensation)	Note 2,4		Note 3,5		Note 4,5		Note 4,6	

Note 2 $T_a \leq 50^\circ\text{C}$: 80% RH max

$T_a > 50^\circ\text{C}$: Absolute humidity must be lower than the humidity of 85%RH at 50°C

Note 3 T_a at -20°C will be <48hrs at 70°C will be <120hrs when humidity is higher than 70%.

Note 4 Background color changes slightly depending on ambient temperature. This phenomenon is reversible.

Note 5 $T_a \leq 70^\circ\text{C}$: 75RH max

$T_a > 70^\circ\text{C}$: absolute humidity must be lower than the humidity of 75%RH at 70°C

Note 6 T_a at -30°C will be <48hrs, at 80°C will be <120hrs when humidity is higher than 70%.

Electrical Characteristics

Item	Symbol	Condition	Min.	Typ	Max.	Unit	note
Power Supply for Logic	$V_{DD}-V_{SS}$	-	4.7	5.0	5.5	Volt	
Input Voltage	V_{IL}	L level	V_{SS}	$0.2 V_{DD}$	-	Volt	
	V_{IH}	H level	$0.8 V_{DD}$	V_{DD}	-	Volt	
LCM Recommend LCD Module Driving Voltage	$V_{lcd}=V_{DD}-V_{O}$	$T_a=-20^{\circ}C$	-	7.1	-	Volt	
		$T_a=0^{\circ}C$	-	6.8	-		
		$T_a=25^{\circ}C$	6.2	6.5	6.8		
		$T_a=50^{\circ}C$	-	6.2	-		
Power Supply for LED B/L	LEDA-LE DK	-	-	5.0	-	Volt	
Power Supply Current for LCM	$I_{DD}(EL\ B/L\ OFF)$	$V_{DD}=5.0V$ $V_{DD}-V_{O}=5.0V$ FLM=64Hz $V_{LED}=5.0V$	-	2.0	3.0	mA	
	$I_{LED}(EL\ B/L\ ON)$		-	200	250		

Optical Characteristics

Item	Symbol	Condition	Min.	Typ	Max.	Unit	note
Viewing angle range	$\Phi f(12\ o'clock)$	When $Cr, \geq 2$	-	20	-	Degree	9,10
	$\Phi b(6\ o'clock)$		-	40	-		
	$\Phi l(9\ o'clock)$		-	30	-		
	$\Phi r(3\ o'clock)$		-	30	-		
Rise Time	T_r	$V_{DD}-V_{O}=5.0V$ $T_a=25^{\circ}C$		150		mS	
Fall Time	T_f			200			
Frame frequency	Frm		-	64	-	Hz	8,10
Contrast	Cr		-	4.0	-		7

Mechanical Specification

Product No.		16032A-201
Module Size		116.0(W)×44.0(H)×13.4max(D)
Dot Size		0.55(W)mm×0.55(H)mm
Dot Pitch		0.59(W)mm×0.59(H)mm
Resolution		160(W)×32(H) Dots Matrix
Duty Ratio		1/32 Duty
LCD Display Mode	STN	<input checked="" type="checkbox"/> Gray Mode <input type="checkbox"/> Yellow Mode <input type="checkbox"/> Blue Mode
	FSTN	<input type="checkbox"/> Black & White(Normally White/Positive Image) <input type="checkbox"/> Black & White(Normally White/Negative Image)
	Rear Polarizer:	<input type="checkbox"/> Reflective <input checked="" type="checkbox"/> Transflective <input type="checkbox"/> Transmissive <input type="checkbox"/> Transflective(High Transmissive)
Viewing Direction		<input checked="" type="checkbox"/> 6 O'clock <input type="checkbox"/> 12 O'clock <input type="checkbox"/> 3 O'clock <input type="checkbox"/> 9 O'clock
Backlight		<input type="checkbox"/> W/O <input type="checkbox"/> CCFL <input type="checkbox"/> EL <input checked="" type="checkbox"/> LED
Controller		Epson SED1521 or compatible
DC/DC Converter		Build in
EL Driver		Without

Interface Pin Assignment

Pin No.	Pin Out	Description
1	A0	Register selection: A0='H' select Data register and A0='L' select Instruction register.
2	CS2	Chip select signal for Half-right screen
3	CS1	Chip select signal for Half=left screen
4	/RD(E)	/RD for 80 serial,E for 68 serial
5	/WR(R/W)	/WR for 80 serial,R/W for 68 serial
6	VDD	Logic Supply Voltage (5V)
7	VSS	GND
8	DB0	3-State I/O Data Bus.
9	DB1	
10	DB2	
11	DB3	
12	DB4	
13	DB5	
14	DB6	
15	DB7	
16	RET	Reset signal The rise of the signal is for active and keep RET='H'
17	V0	LCD Driver Supply Voltage
18	VEE	Nogtave voltage output
19	LEDA	Backlight driver supply voltage(+5V)
20	LEDK	Backlight driver supply voltage(0V)

[Note 7] Definition of Operation Voltage (Vop)

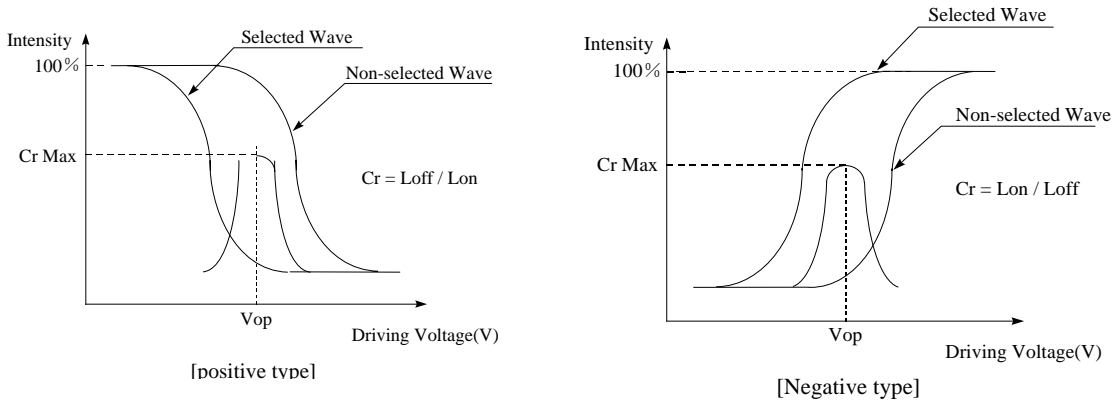

[Note 8] Definition of Response Time (Tr, Tf)

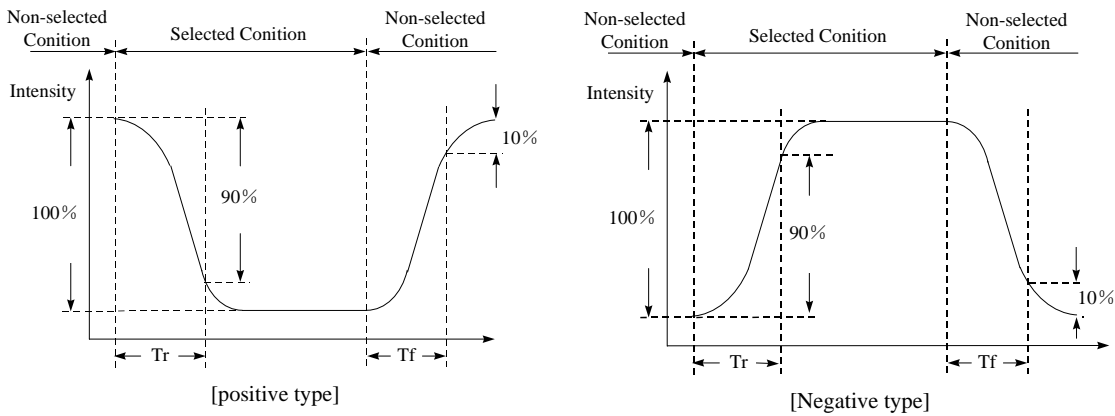

Conditions:

Operating Voltage : V_{op}

Frame Frequency : 64 Hz

Viewing Angle (θ, φ): $0^\circ, 0^\circ$

Driving Wave form : 1/N duty, 1/a bias

[Note 9] Definition of Viewing Direction

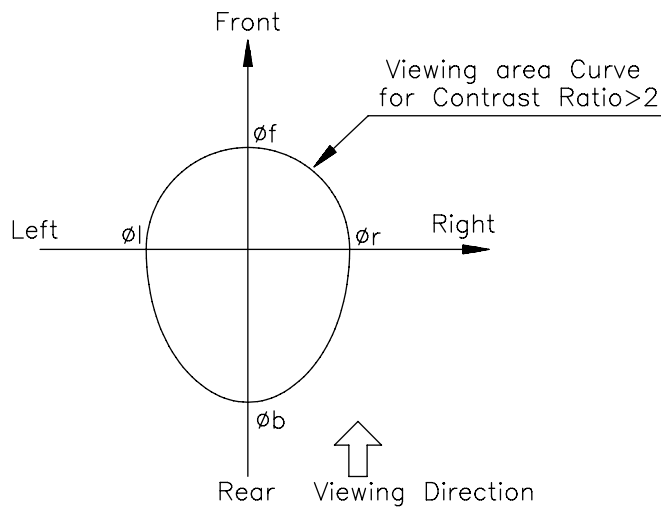

[Note 10] Definition of viewing angle

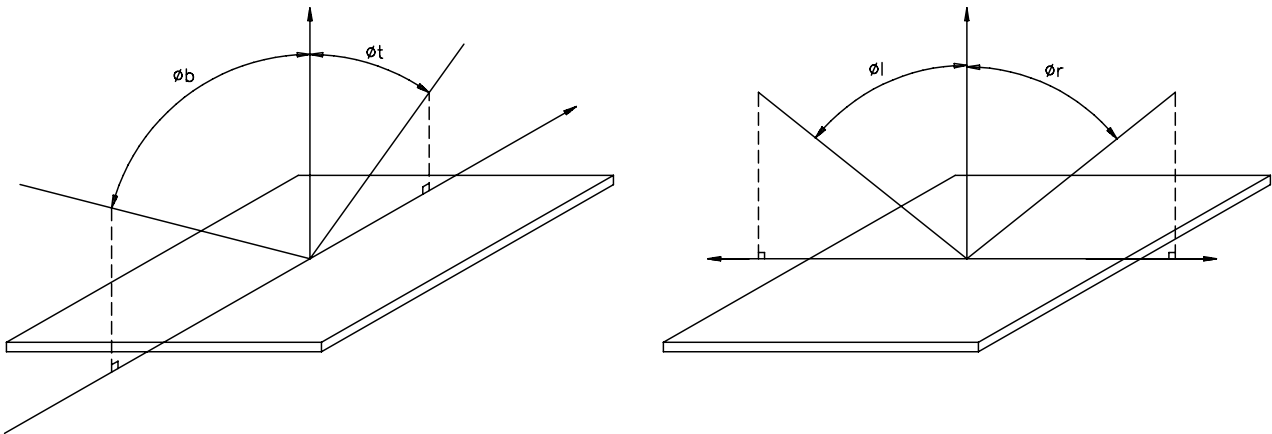

[Note 11] Description of Measuring Equipment

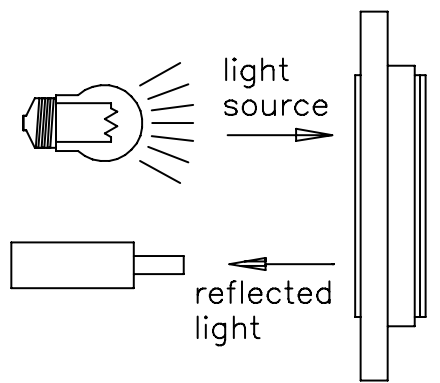

Reflective type

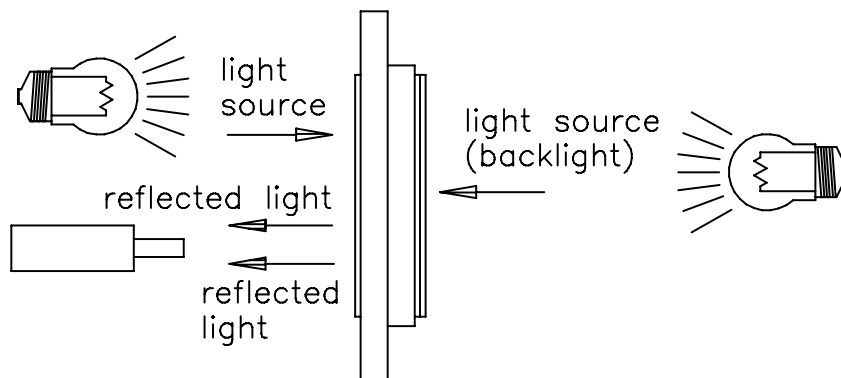

Transflective type

Block Diagram

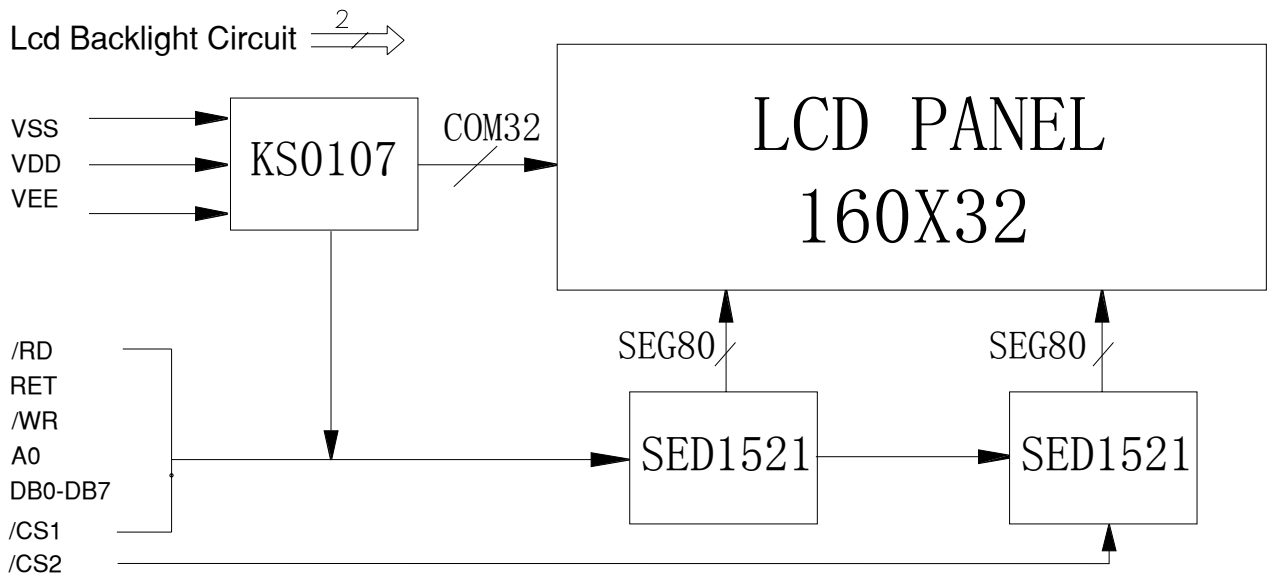

Power Supply

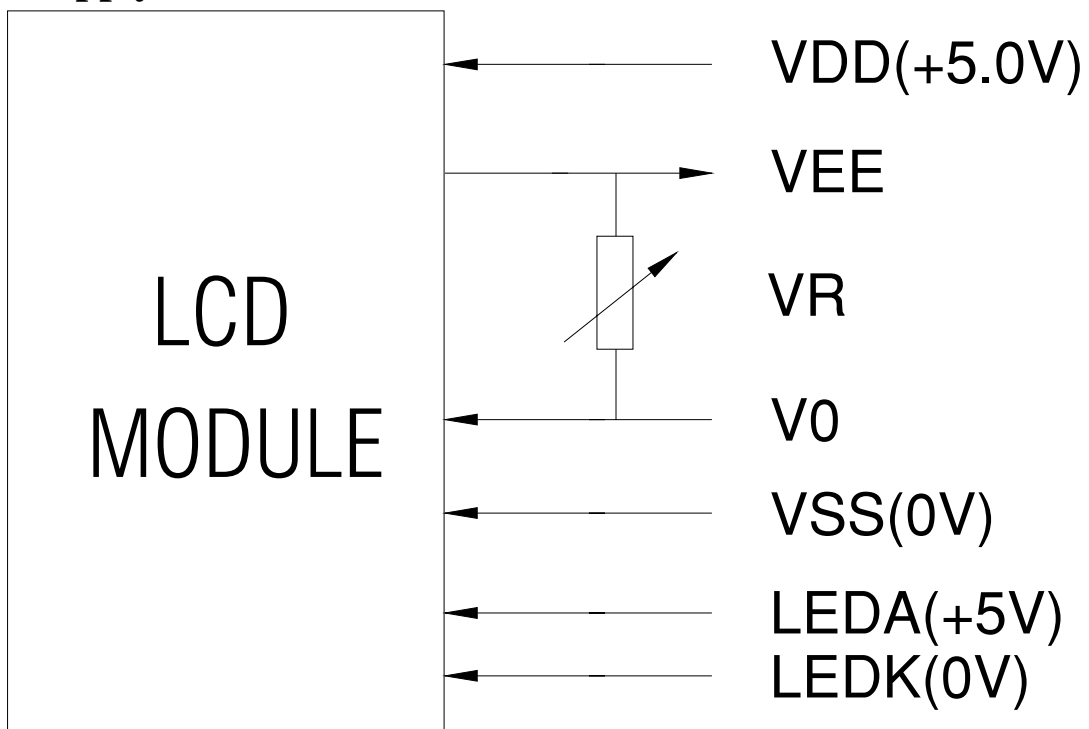

Timing Characteristics

AC Characteristic—68-series MPU Bus Read/Write

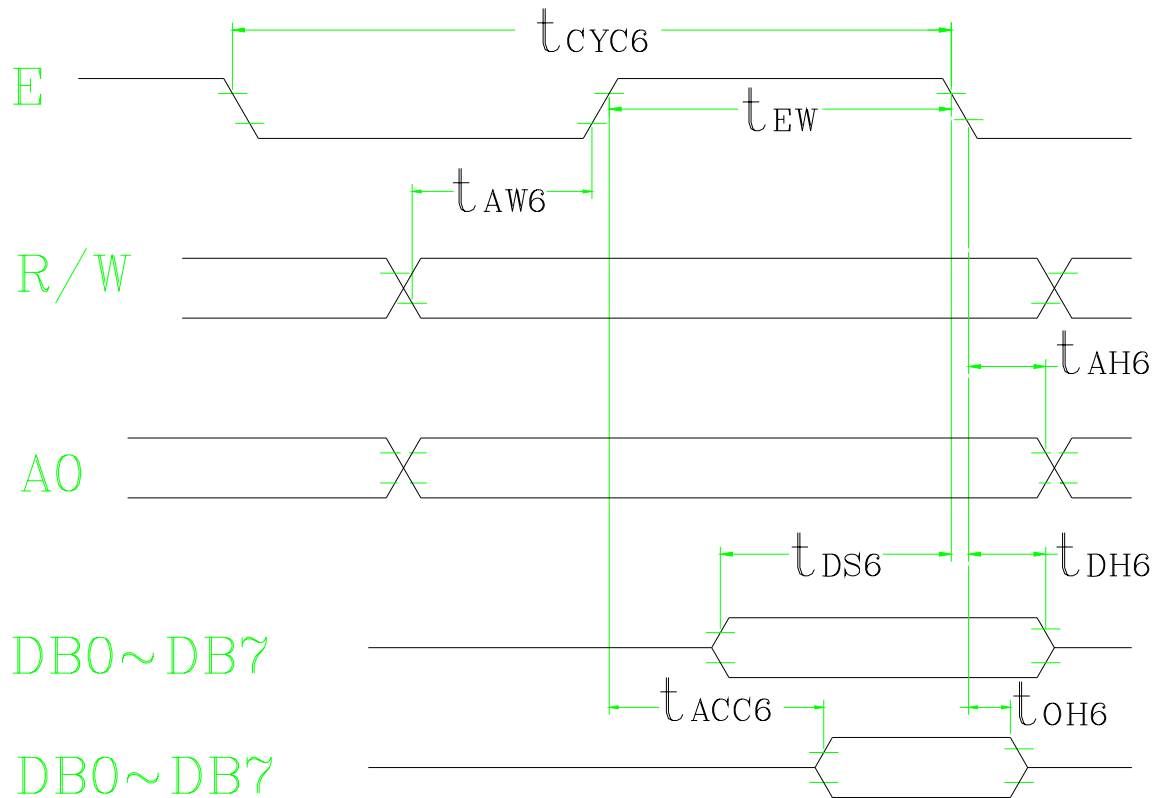

Read/Write Timing for
the 68-port MPU

Ta=0~50°C, V_{DD}=5.0V±10%, unless state otherwise

Parameter	Symbol	Condition	Rating		Unit	Signal
			Min.	Max.		
Address hold time	t _{AH6}	-	10	-	ns	Ao,
Address setup time	t _{AW6}	-	20	-	ns	
System cycle time	t _{CYC6}	-	1000	-	ns	R/W
Control pulse-width	t _{CC}	-	200	-	ns	
Data setup time	t _{DS6}	-	80	-	ns	D0 to D7
Data hold time	t _{DH6}	-	10	-	ns	
RD access time	t _{ACC6}	C _L =100pF	-	90	ns	
Output disable time	t _{CH6}		10	60	ns	
Rise and fall time	t _r , t _f	-	-	15	ns	-
Enable pulse width	R/ /W	T _{EW}	100	-	ns	E
			80	-	ns	

Display Data Ram Addressing

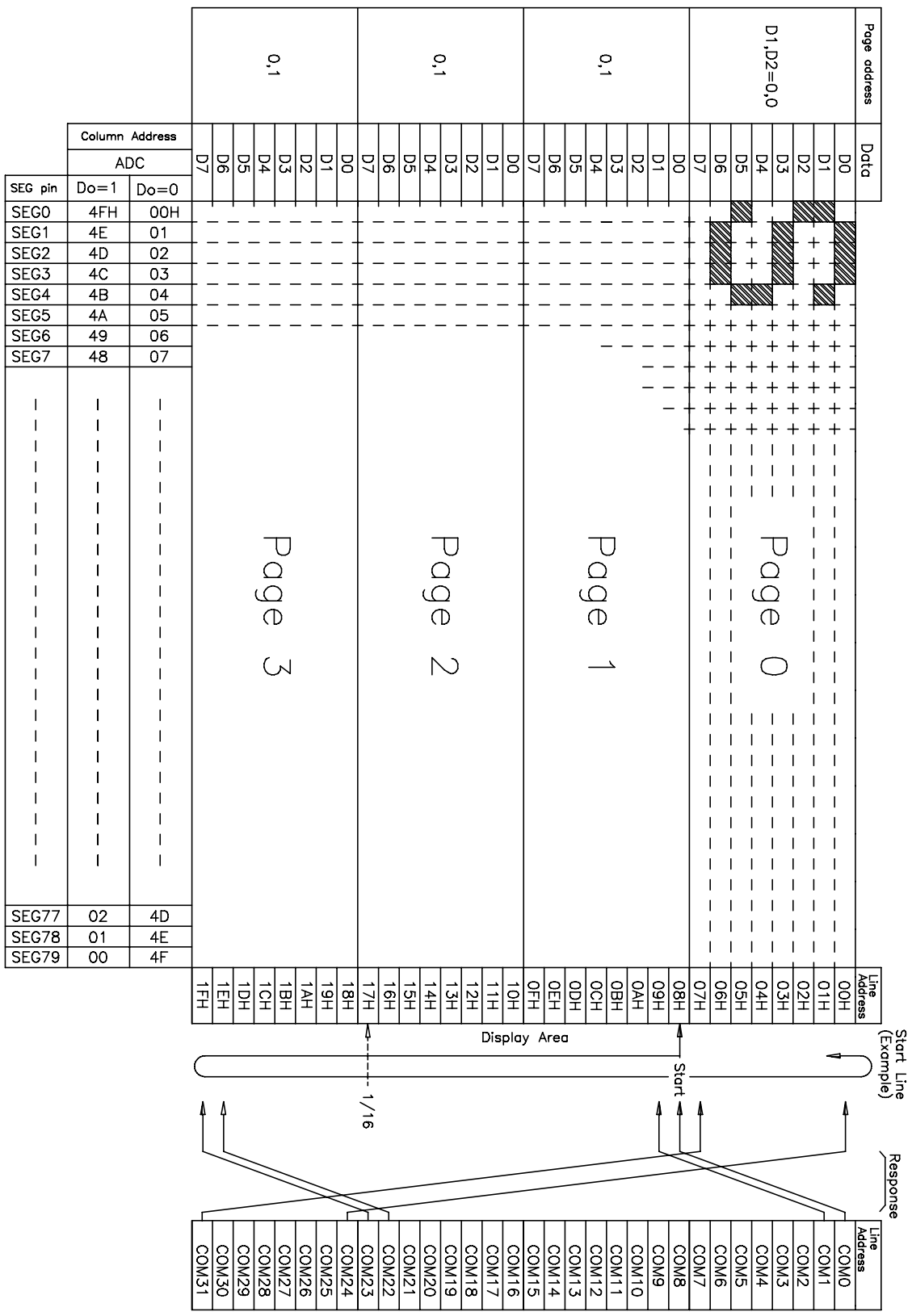

Display Commands

Instruction	A0	RD	WR	D7	D6	D5	D4	D3	D2	D1	D0	Function
Display ON/OFF	0	1	0	1	0	1	0	1	1	1	1/0	To control the display ON or OFF. The internal status and display RAM data are not affected. 0:OFF, 1:ON
Display start line	0	1	0	1	1	0	Display start address (0~31)				Specifies RAM line corresponding to top line of display.	
Set page address	0	1	0	1	0	1	1	1	0	Page (0 to 3)		To set the display RAM page in page address register.
Set column (segment) address	0	1	0	0	Column address (0 to 79)							To set display RAM column address in column address register.
Status Read	0	0	1	Busy	ADC	ON/OFF	Reset	0	0	0	0	Read the following status: Busy 1: Busy 0: Ready ADC 1: CW output 0: CCW output ON/OFF 1: Display OFF 0: Display ON Reset 1: Being reset 0: Normal
Write display data	1	1	0	Write Data							To write data from data bus to display RAM.	
Read display data	1	0	1	Read Data							To read data from display RAM to data bus	
Select ADC	0	1	0	1	0	1	0	0	0	0	0/1	0: CW output, 1: CCW output
Status drive ON/OFF	0	1	0	1	0	1	0	0	1	0	0/1	To select static driving operation 1: Static drive, 0: Normal driving
Select Duty	0	1	0	1	0	1	0	1	0	0	0/1	To select duty cycle 1: 1/32 duty, 0: 1/16 duty
Read-modify-write	0	1	0	1	1	1	0	0	0	0	0	Read-modify-write ON
End	0	1	0	1	1	1	0	1	1	1	0	Read-modify-write OFF
Reset	0	1	0	1	1	1	0	0	0	1	0	To reset by software

Command Description

Display ON/OFF

A0	RD	WR	D7	D6	D5	D4	D3	D2	D1	D0	
0	1	0	1	0	1	0	1	1	1	D	AEH, AFH

This command turns the display ON or OFF.

D=1 : Display ON

D=0 : Display OFF

Display Start Line

This command specifies the line address shown in page 14 and indicates the display line that corresponding to COM 0. The display area begins at the specified line address and continues in the line address increment direction. This area having the number of line of specified display duty is displayed. If the line address is changed dynamically by this command, the vertical smooth scrolling and paging can be used.

A0	RD	WR	D7	D6	D5	D4	D3	D2	D1	D0	
0	1	0	1	1	0	A4	A3	A2	A1	A0	C0H to DFH

This command loads the display start line register.

A4	A3	A2	A1	A0	Line Address
0	0	0	0	0	0
0	0	0	0	1	1
		⋮			⋮
1	1	1	1	1	31

See the figure in page 14.

Set Page address

This command specifies the page address that corresponds to the low address of the display data RAM when it is accessed by the MPU. Any bit of the display data RAM can be accessed when its page address and column address are specified. The display status is not changed even when the page address is changed.

A0	RD	WR	D7	D6	D5	D4	D3	D2	D1	D0	
0	1	0	11	0	1	1	1	0	A1	A0	B8H to BBH

This command loads the page address register.

A1	A0	Page
0	0	0
0	1	1
1	0	2
1	1	3

See the figure in page 14.

Set Column Address

This command specifies a column address of the display data RAM. When the display data RAM is accessed by the MPU continuously, the column address is increased by 1 every time. Therefore the MPU can access to data continuously. The column address stops to be incremented at address 80, and the page address is not changed continuously.

A0	RD	WR	D7	D6	D5	D4	D3	D2	D1	D0	00H to 4FH
0	1	0	0	A6	A5	A4	A3	A2	A1	A0	

This command loads the column address register.

A6	A5	A4	A3	A2	A1	A0	Line Address
0	0	0	0	0	0	0	0
0	0	0	0	0	0	1	1
			⋮				⋮
1	1	1	1	1	1	1	79

Read Status

A0	RD	WR	D7	D6	D5	D4	D3	D2	D1	D0	00H to 4FH
0	0	1	BUSY	ADC	ON/OFF	RESET	0	0	0	0	

Reading the command I/O register (Ao=0) yields system status information.

- The busy bit indicates whether the driver will accept a command or not.
 Busy=1: The driver is currently executing a command or is resetting. No new command will be accepted.
 Busy=0: The driver will accept a new command.
- The ADC bit indicates the way column addresses are assigned to a segment drivers
 ADC=1: Normal. Column address $n \rightarrow$ segment address n .
 ADC=0: Inverted. Column address $79-u \rightarrow$ segment driver u .
- The ON/OFF bit indicates the current status of the display.
 It is the inverse of the polarity of the display ON/OFF command.
 ON/OFF=1: Display OFF.
 ON/OFF=0: Display ON.
- The RESET bit indicates whether the driver is executing a hardware or a software reset or it is in a normal operating mode.
 RESET=1: Currently executing the reset command.
 RESET=0: Normal operating.

Write Display Data

A0	RD	WR	D7	D6	D5	D4	D3	D2	D1	D0
1	1	0	Write Data							

To write an 8-bit data into the display RAM, at a location specified by the contents of the column address and page address register by one.

Read Display Data

A0	RD	WR	D7	D6	D5	D4	D3	D2	D1	D0
1	0	1	Read Data							

To read an 8-bit data from the data I/O latch, updates the contents of the I/O latch with display data from the display data RAM location specified by the contents of the column address and page address registers and then increments the column address register.

After loading a new address into the column address register one dummy read is required before valid data is obtained.

Select ADC

A0	RD	WR	D7	D6	D5	D4	D3	D2	D1	D0
0	1	0	1	0	1	0	0	0	0	D

 A0H, A1H

This command selects the relationship between display data RAM column address and segment driver.

D=0: SEG0 ← column address 00H, ...(normal)

This command is provided to reduce restrictions on the placement of the driver ICs and routing of tracing during printed circuit board layout. In this LCD module the D should be cleared to 0.

Static Driver ON/OFF

A0	RD	WR	D7	D6	D5	D4	D3	D2	D1	D0
0	1	0	1	0	1	0	0	1	0	D

 A4H, A5H

To force the display on and all common outputs to be selected.

D=1: Static driver ON.

D=0: Static driver OFF.

Select Duty

A0	RD	WR	D7	D6	D5	D4	D3	D2	D1	D0
0	1	0	1	0	1	0	1	0	0	D

 A8H, A9H

To set the D-bit to 1 because the LCD module is 1/32 duty.

End

A0	RD	WR	D7	D6	D5	D4	D3	D2	D1	D0
0	1	0	1	1	1	0	1	1	1	0

 EEH

This command cancels the **Read-Modify-Write** mode and restores the contents of the column address register to their value prior to the receipt of the **Read-Modify-Write** command.

Reset

A0	RD	WR	D7	D6	D5	D4	D3	D2	D1	D0
0	1	0	1	1	1	0	0	0	1	0

 E2H

This command clears:

Set the 1st line in the display start line register and to set page address register to 3 page.

It does not affect the contents of the display data RAM. When the power supply is turned on, the user must send a Reset signal into the RES pin. The Reset command cannot be used instead of this Reset signal.

Read-Modify-Write

A0	RD	WR	D7	D6	D5	D4	D3	D2	D1	D0	
0	1	0	1	1	1	0	0	0	0	0	E0H

This command defeats column address register auto-increment after reading data. The current contents of the column address register are saved. This mode remains active until an **END** command is received.

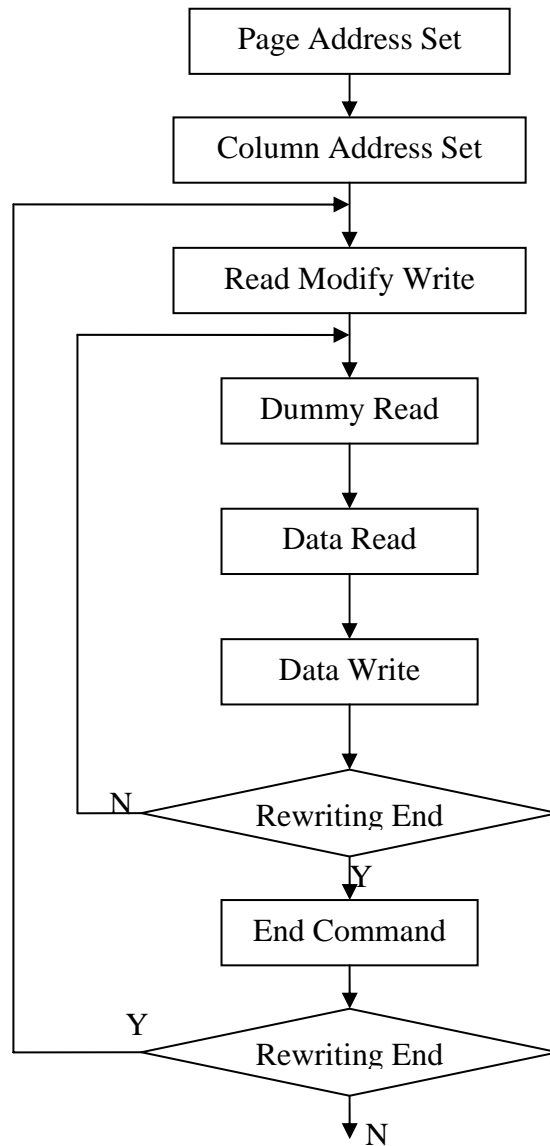

Initialization Procedure

Detects a rising edge or falling edge of an RES input and initializes the MPU during power-on.
Initialization status:

1. Display is OFF
2. Display start line register is set to line 1
3. Static drive is turn off
4. Column address counter is set to address 0.
5. Page address register is set to page 3.
6. 1/32 duty is selected.
7. Forward ADC is selected(ADC command D0 is 1 and ADC status flag is 1)
8. Read-modify-write is OFF.

Reliability Test

No	Item	Conditions		Note
1	High Temp. Operation	50°C	120HR	
2	High Temp. Storage	70°C	120HR	
3	Low Temp. Operation	0°C	120HR	
4	Low Temp. Storage	-20°C	120HR	
5	High Temp./Humid Storage	60°C 90%RH	120HR	
6	Thermal Shock	-20°C ,30min +60°C ,30min	10 cycle	
7	Vibration Test (IEC-68-2-6)	Frequency : 10~55 Hz Duration : 20 times, 6 min/time Amplitude : 0.75 mm	-	
8	Shock (IEC 68-2-27)	Duration : 11 mS Acceleration : 100g	-	X, Y, Z direction

Appearance Check

CONDIITON OF APPEARANCE CHECK:

- (1) Specimen shall be checked by eyes in distance of 30cm under 40w-fluorescence lamp.
- (2) Checking direction shall be in 45 degree from perpendicular line op specimen surface.



Handling Precautions

- (1) Treat polarizer very carefully since it is easy to be damaged.
- (2) When cleaning the display surface, use soft cloth (e.g. gauze) with a solvent (recommended below) and wipe lightly.
 - ◆ ethyl alcohol
 - ◆ iso-propanol

Do not wipe the display surface with dry or hard materials that will damage the polarizer surface.

Do not use the following solvents:

- ◆ water
- ◆ ketone
- ◆ aromatics

- (3) Direct current causes electro-chemical reaction with remarkable degradation of the display quality. Give careful consideration to prevent direct current at ON/OFF timing and during operation.
- (4) Avoid strong shock and drop from the height.
- (5) To prevent LCD panels from degradation, do not operate or store them exposed directly to sunshine or high temperature/humidity.
- (6) Give careful consideration to avoid electrical static discharge which causes uneven contrast.
- (7) Even a small condensation on the contact pads (terminals) causes electro-chemical reaction which makes missing row and column. Give careful attention to avoid condensation. When assembling with zebra connector, clean the surface of the pads with alcohol and keep the air very clean.

Lcd Product Quality Standard

DISPLAY APPEARANCE

No	Item	Criteria
1	inclusions (black spot, white spot, dust)	(1)round type diameter mm(a*) no of defect* $a \leq 0.20$ neglect $0.20 < a \leq 0.35$ 5max $0.35 < a$ none (2)linear type length mm(l) width mm(W) no. of defect na $W \leq 0.03$ neglect $1 \leq 3$ $0.03 < W \leq 0.08$ 6 $3 < l$ $0.08 < W$ none
2	scratch	1. scratch on protective film is permitted. 2. scratch on polarizer shall be as follow: (1)round type diameter mm(a*) no of defect $a \leq 0.15$ neglect $0.15 < a \leq 0.20$ 2 max $0.20 < a$ none (2)linear type be judged by 1.-(2) linear type
3	dent	diameter < 1.5mm
4	bubble	not exceeding 0.5mm average diameter is acceptable between glass and polarizing film
5	pin hole	$(a+b)/2 \leq 0.15\text{mm}$ maximum number: ignored $0.15 < (a+b)/2 \leq 0.20\text{mm}$ maximum number: 10
6	dot defect	$(a+b)/2 \leq 0.20\text{mm}$ maximum number: ignored $0.20 < (a+b)/2 \leq 0.30\text{mm}$ maximum number: 5 x=width
7	contrast irregularity(spot)	diameter spec no of defect $a \leq 0.50\text{mm}$ neglect $0.50 < a \leq 0.75$ 5 $0.75 < a \leq 1.00$ 3 $1.00 < a$ none
8	dot width	design width $\pm 15\%$
9	color tone and uniformity	obvious uneven color is not permitted

Interface circuit and driving programme on LCM of dots matrix series .

一. Interface circuit:

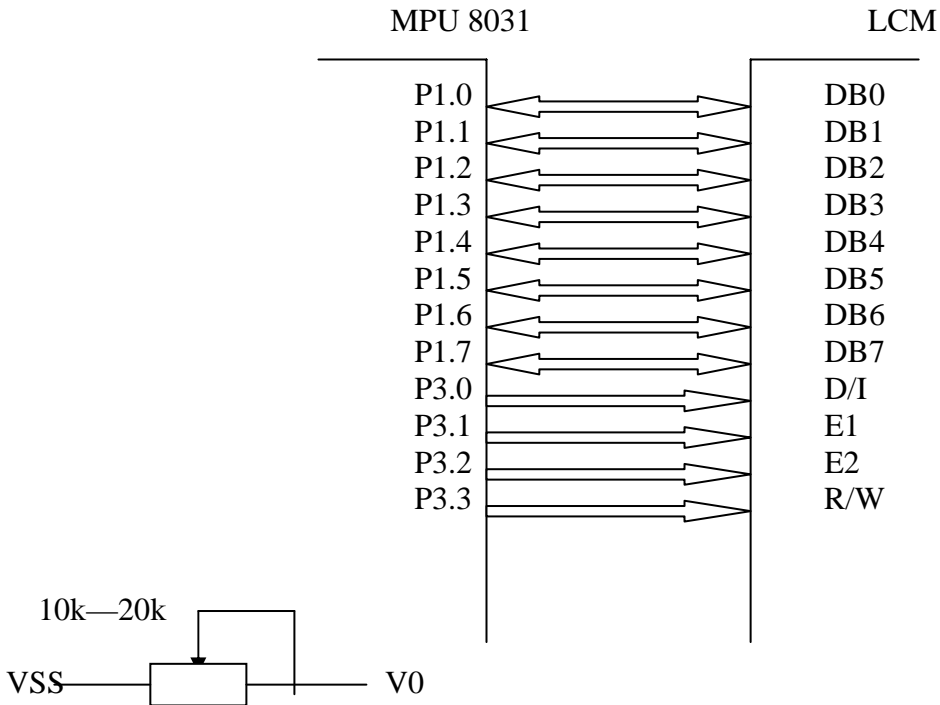

二. Driving programme

```
#include<reg51.h>

sbit di=P3^0;
sbit e1=P3^1;
sbit e2=P3^2;
sbit rw=P3^3;

unsigned char x,y;

void delay(int num)
{
    while(num--);
}

void send_command(unsigned char cmd)
{
    e1=e2=0;
    di=rw=0;
    P1=cmd;
+   e1=e2=1;
```

```

    delay(2);
    e1=e2=0;
    delay(2);
    P1=0xff;
    e1=e2=1;
}

void lw(unsigned char x,unsigned char y,unsigned char dd) {
    if (x<61)
        {
            e1=e2=1;
            di=rw=0;P1=0xb8|y;e1=1;delay(2);e1=0;delay(2);
            e1=e2=1;
            di=rw=0;P1=0x00|x;e1=1;delay(2);e1=0;delay(2);
            e1=e2=1;
            di=1;rw=0;P1=dd;e1=1;delay(2);e1=0;delay(2);
            e1=e2=1;
        }
    else
        {
            x=x-61;e1=e2=1;
            di=rw=0;P1=0x00|x;e2=1;delay(2);e2=0;delay(2);
            e1=e2=1;
            di=rw=0;P1=0xb8|y;e2=1;delay(2);e2=0;delay(2);
            e1=e2=1;
            di=1;rw=0;P1=dd;e2=1;delay(2);e2=0;delay(2);
            e1=e2=1;
        }
    P1=0xff;
}

```

```

void lcd_init(void) {
    unsigned char x,y;
    e1=e2=0;
    di=rw=0;
    send_command(0xae);
    send_command(0xc0);
    send_command(0xa4);
    send_command(0x00);
    send_command(0xbb);
    send_command(0xa9);
    send_command(0xa0);
    send_command(0xee);

    for (y=0;y<4;y++)
        {
            for (x=0;x<122;x++) lw(x,y,0);
        }
    send_command(0xaf);
}

```

}

unsigned char

a[16]={0xff,0x00,0x00,0xff,0xaa,0xaa,0x55,0x55,0xaa,0x55,0x55,0xaa,0xff,0xff,0x00,0x00};

unsigned char code

yu[32]={0x00,0x00,0x88,0x88,0x4A,0xAC,0xB8,0xAA,0xBC,0xA8,0xB8,0xAC,0x4A,0x88,0x88,0x00,0x00,0x00,0x00,0x00,0x3A,0x2A,0x2A,0x2A,0x2A,0x2A,0x2A,0x2A,0x3A,0x00,0x00,0x00};

unsigned char code

xin[32]={0x00,0x00,0x80,0x60,0xF8,0x06,0x08,0xA8,0xA8,0xAA,0xAC,0xA8,0xA8,0xA8,0x08,0x00,0x00,0x00,0x00,0x00,0x3F,0x00,0x00,0x3E,0x12,0x12,0x12,0x12,0x12,0x3E,0x00,0x00};

unsigned char code

dian[32]={0x00,0x00,0xF0,0x90,0x90,0x90,0x90,0xFE,0x90,0x90,0x90,0x90,0xF0,0x00,0x00,0x00,0x00,0x00,0x0F,0x04,0x04,0x04,0x04,0x1F,0x24,0x24,0x24,0x24,0x27,0x20,0x18,0x00};

unsigned char code

zi[32]={0x00,0x00,0x80,0x82,0x82,0x82,0x82,0x82,0xE2,0x92,0x8A,0x86,0x82,0x80,0x80,0x00,0x00,0x00,0x00,0x00,0x00,0x10,0x20,0x1F,0x00,0x00,0x00,0x00,0x00,0x00,0x00,0x00};

unsigned char code

you[32]={0x00,0x00,0x04,0x84,0x44,0xF4,0x9C,0x96,0x94,0x94,0x94,0x94,0xF4,0x04,0x04,0x00,0x00,0x00,0x01,0x00,0x00,0x3F,0x04,0x04,0x04,0x14,0x24,0x24,0x1F,0x00,0x00,0x00};

unsigned char code

xian[32]={0x00,0x00,0xFE,0x02,0x22,0x5A,0x86,0x00,0xFE,0x92,0x92,0x92,0x92,0xFE,0x00,0x00,0x00,0x00,0x3F,0x04,0x08,0x04,0x03,0x00,0x3F,0x12,0x04,0x0A,0x11,0x30,0x10,0x00};

unsigned char code

gong[32]={0x00,0x00,0x80,0x80,0x40,0x30,0x0C,0x00,0xC0,0x06,0x18,0x20,0xC0,0x80,0x80,0x00,0x00,0x00,0x00,0x10,0x18,0x14,0x12,0x11,0x10,0x10,0x14,0x18,0x30,0x00,0x00,0x00};

unsigned char code

si[32]={0x00,0x00,0x10,0x92,0x92,0x92,0x92,0x92,0x92,0x92,0x12,0x02,0x02,0xFE,0x00,0x00,0x00,0x00,0x00,0x1F,0x08,0x08,0x08,0x08,0x08,0x1F,0x00,0x10,0x20,0x1F,0x00,0x00};

unsigned char code

d[32]={0x00,0x00,0x00,0xC0,0x40,0x40,0x40,0x7E,0x48,0x48,0x48,0x48,0xC8,0x08,0x00,0x00,0x00,0x00,0x20,0x1B,0x02,0x02,0x0A,0x32,0x02,0x0A,0x32,0x02,0x0B,0x10,0x20,0x00};

unsigned char code

zhen[32]={0x00,0x00,0xFE,0x22,0x5A,0x86,0x08,0xC8,0xB8,0x8E,0xE8,0x88,0x88,0x88,0x08,0x00,0x00,0x00,0x3F,0x02,0x04,0x03,0x04,0x04,0x04,0x04,0x3F,0x04,0x04,0x04,0x04,0x00};

unsigned char code

ye[32]={0x00,0x00,0x12,0x24,0x8C,0x00,0x84,0xC4,0x34,0xC4,0xB6,0x24,0x24,0xE4,0x04,0x00,0x00,0x00,0x02,0x3F,0x00,0x01,0x00,0x3F,0x21,0x12,0x0C,0x05,0x0B,0x30,0x20,0x00};

unsigned char code

jìn[32]={0x00,0x00,0x00,0x80,0x80,0xBE,0xAA,0xAA,0x2A,0xAA,0xAA,0xBE,0x80,0x80,0x00,0x00,0x00,0x00,0x3F,0x24,0x24,0x24,0x3F,0x00,0x3F,0x24,0x24,0x24,0x3F,0x00,0x00};

unsigned char code

xi[32]={0x00,0x00,0x00,0x00,0xFE,0x92,0x92,0x92,0x92,0x92,0x92,0x92,0xFE,0x00,0x00,0x00,0x00,0x00,0x21,0x22,0x26,0x20,0x3F,0x20,0x20,0x20,0x3F,0x20,0x24,0x22,0x23,0x00};

unsigned char code

s[32]={0x00,0x00,0x20,0x22,0x22,0x22,0x22,0xE2,0x22,0x22,0x22,0x22,0x22,0x20,0x00,0x00,0x00,0x08,0x04,0x02,0x03,0x10,0x20,0x1F,0x00,0x00,0x01,0x02,0x04,0x0C,0x00};

unsigned char code

mo[32]={0x00,0x00,0x10,0xD0,0xFE,0x50,0x94,0xF4,0x5E,0x54,0x54,0x54,0x5E,0xF4,0x04,0x00,

```

0x00,0x00,0x03,0x00,0x3F,0x00,0x24,0x25,0x15,0x0D,0x07,0x0D,0x15,0x25,0x24,0x00};
unsigned char code
kuai[32]={0x00,0x00,0x20,0x20,0xFE,0x20,0x20,0x10,0x10,0xFE,0x10,0x10,0x10,0xF0,0x00,0x00,
0x00,0x00,0x08,0x08,0x0F,0x24,0x25,0x11,0x0D,0x03,0x05,0x09,0x11,0x21,0x21,0x00};

```

```

void write_chinese(x,y,array)
unsigned char x,y;
unsigned char array[];
{
    unsigned char j,dd;
    for(j=0;j<32;j++)
    {
        dd=array[j];
        if(j<16) lw(x+j,y,dd);
        else     lw(x+j-16,y+1,dd);
    }
}

```

```

void main()
{
    unsigned char i,dd;
loop:   lcd_init();
        write_chinese(0,0,yu);
        write_chinese(16,0,xin);
        write_chinese(31,0,dian);
        write_chinese(46,0,zi);
        write_chinese(61,0,you);
        write_chinese(77,0,xian);
        write_chinese(92,0,gong);
        write_chinese(107,0,si);

        write_chinese(0,2,d);
        write_chinese(16,2,zhen);
        write_chinese(31,2,ye);
        write_chinese(46,2,jin);
        write_chinese(61,2,xi);
        write_chinese(77,2,s);
        write_chinese(92,2,mo);
        write_chinese(107,2,kuai);
        delay(60000);
        for(i=0;i<8;i++)
        {
            for(y=0;y<4;y++)
            {
                for(x=0;x<122;x++)
                {
                    if(x%2==0)
                        lw(x,y,a[2*i]);
                    else

```

```
        lw(x,y,a[2*i+1]);  
    }  
        }  
        delay(60000);  
    }  
goto loop;
```

Revision History

