DOCUMENT REVISION HISTORY

Version	DATE	DESCRIPTION	CHANGED BY
V0	07-06-2009	First Issue	Khan.wan

CONTENTS

1. Features & Mechanical specifications	4
2. Absolute Maximum Ratings	5
3. DC Electrical Characteristics	5
4. Backlight Characteristics.....	5
5. Electro-Optical Characteristics.....	6
6. Touch screen characteristics.....	9
7. Dimensional Outline	10
8. Module Function Description	11
9. Reliability Testing	14
10. Quality Specification.....	15
11. Precautions for Using LCD Module.....	18

1. Features & Mechanical Specifications

Item	Contents	Unit
LCD Type	TFT , Negative , Transmissive	—
Viewing direction	12 o'clock	—
Backlight	White LED Backlight	—
Interface	8080 8/16-bit parallel interface	—
Driver IC	ILI9325	—
Outline Dimension	42.72(W) x60.46(H) x4.0(MAX)(T)	mm
Active area (WxH)	36.72 x48.96	mm
Number of Dots	240(RGB) x 320	Dots
Pixel pitch (WxH)	0.153x 0.153	mm
Operating Temperature	-20 ~ +70	°C
Storage temperature	-30 ~ +80	°C

2. Absolute Maximum Ratings

Item	Symbol	Condition	Min.	Max.	Unit
System Power Supply Voltage	VDD	—	-0.3	+4.6	V
Input voltage	Vin	—	-0.3	VDD+0.3	V
Operating Temperature	TOP	—	-20	+70	°C
Storage Temperature	TST	—	-30	+80	°C
Storage Humidity	HD	Ta<40°C	20	90	%RH

Note: If the module is used above these absolute maximum ratings, it may become permanently damaged. Using the module within the above electrical characteristic limit is strongly recommended for normal operation.

3. DC Electrical Characteristics

GND=0V, Ta=25°C

Item	Symbol	Condition	Min.	Typ.	Max.	Unit
Power Supply Voltage	VDD	—	2.4	2.8	3.3	V
Input High Voltage	VIH	—	0.8VDD	—	VDD	V
Input Low Voltage	VIL	—	-0.3	—	0.2 VDD	V
Output High Voltage	VOH	—	0.8VDD	—	—	V
Output Low Voltage	VOL	—	—	—	0.2 VDD	V
Supply Current	ICC	VDD=2.8V	—	10	15	mA

4. Backlight Characteristics

Item	Symbol	Conditions	Min.	Typ.	Max.	Unit
Forward Voltage	VF	IF=15*4mA	2.8	3.0	3.2	V
Reverse Current	IR	Vr=5V	—	—	15	μA
Average Brightness	IV	IF=15*4mA	2800	—	—	cd/m ²
CIE Color Coordinate	X	IF=15*4mA	0.26	—	0.29	—
	Y		0.26	—	0.29	—
Color	White					

5. Electro-Optical Characteristics

Item	Symbol	Condition	Min.	Typ.	Max.	Unit	Remark	
Response time	Tr+Tf	$\theta_x = \theta_y = 0$	—	30	40	ms	Reference only	
Contrast ratio	CR		—	300	—	—		
Transmittance	T%		4.5	5	—	%		
Color chromaticity	White		Wx	0.288	0.308	0.328		—
			Wy	0.322	0.342	0.362		—
	Red		Rx	0.633	0.653	0.673		—
			Ry	0.311	0.331	0.351		—
	Green		Gx	0.291	0.311	0.331		—
			Gy	0.554	0.574	0.594		—
Blue	Bx		0.114	0.134	0.154	—		
	By	0.114	0.134	0.154	—			
Viewing angle	Hor.	θ_{x+}	50	65	—	°		
		θ_{x-}	50	65	—			
	Ver.	θ_{y+}	45	60	—	°		
		θ_{y-}	35	50	—			

5.1 Definition of Viewing Angle

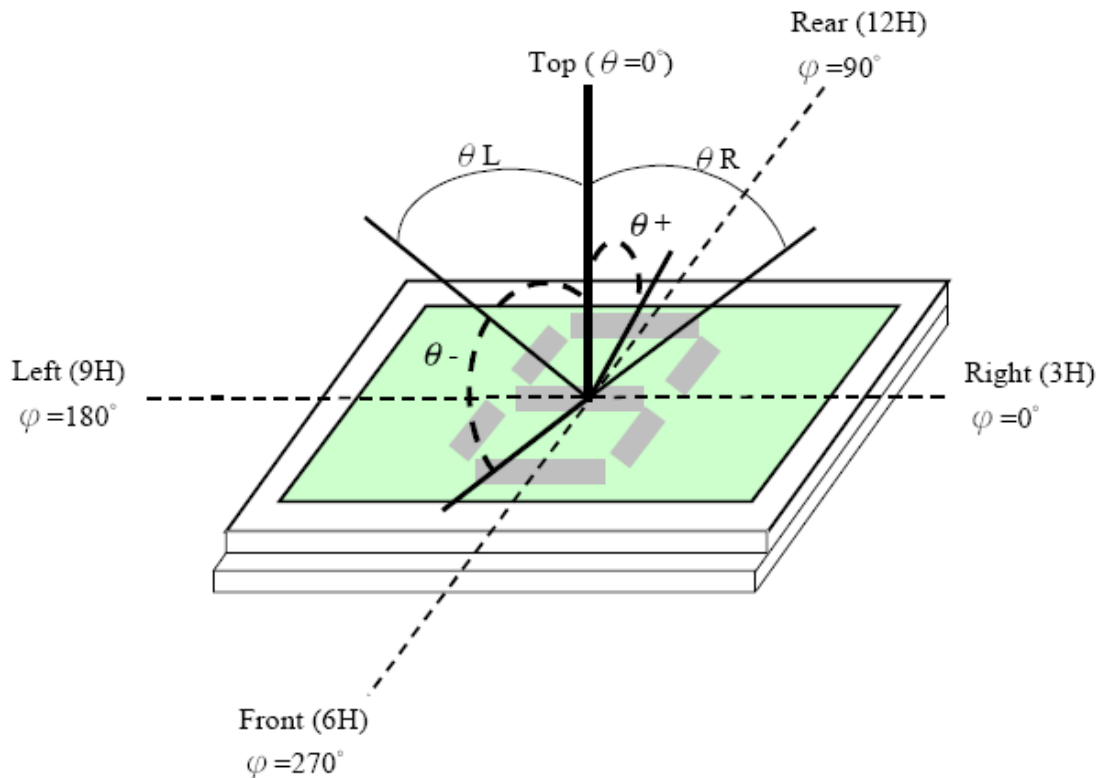

Viewing angle

5.2 Definition of Response Time

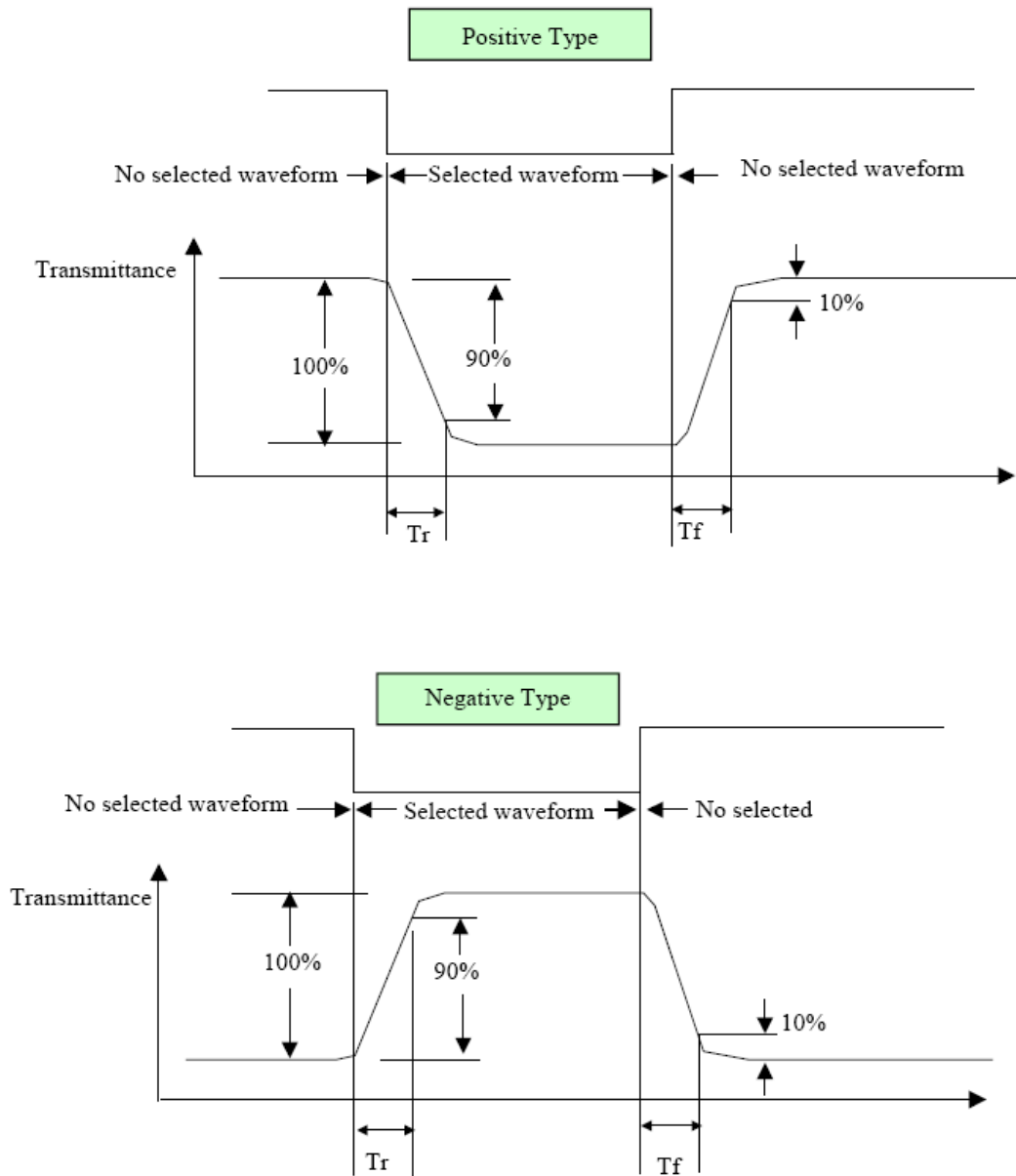

5.3 Definition of V_{th}

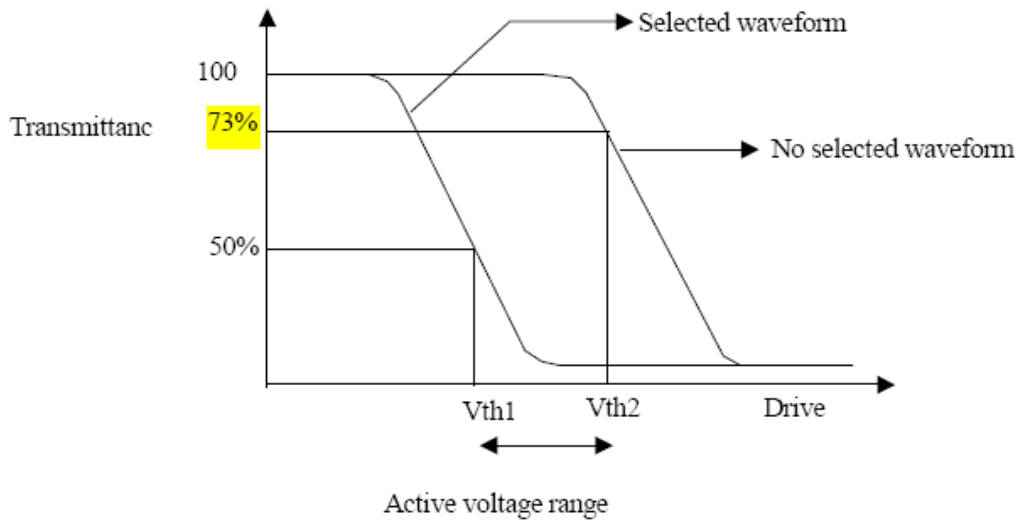

	V_{th1}	V_{th2}
View direction	10°	40°
Drive waveform	(Selected waveform)	(No selected waveform)
Transmittance	50%	73%

※1 Contrast ratio
 = (Brightness in OFF state) / (Brightness in ON state)

Outline of Electro-Optical Characteristics Measuring System

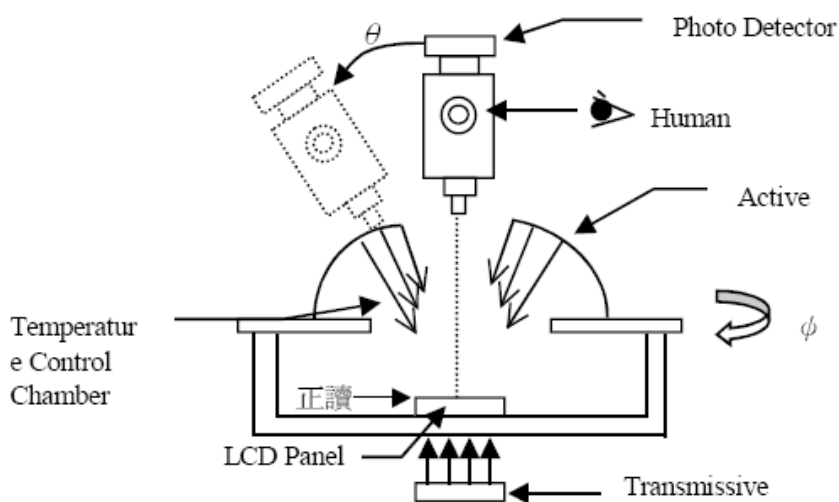

Measuring System: Autronic DMS-803

6. Touch screen characteristics

Item	Specification
Input Method	ABS Pen
ITO Glass	T=0.7mm , 400 Ω / \square
ITO Film	T=0.18mm , 400 Ω / \square
Surface Hardness	铅笔硬度 2H 以上
Insulation Impedance	DC7.5V,20M Ω 以上
Light Transparency	80%min.
Linearity	\leq 1.5%
Physics Resume	<15ms
Operation Pressure	30~150g
MAX Pressure	1000gf
Operation Voltage.	5V DC. Max Voltage : 7V DC.

7. Dimensional Outline

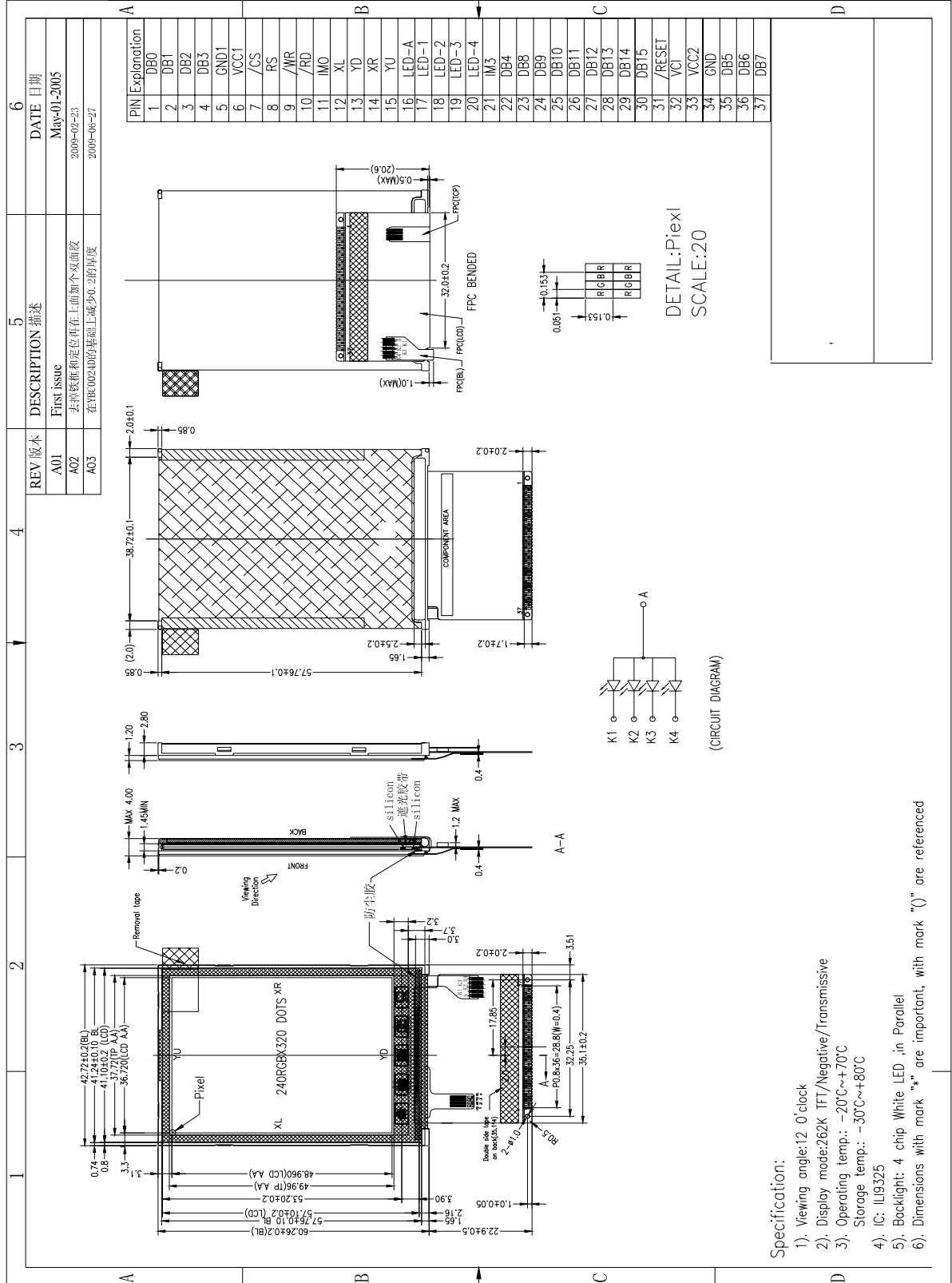

8. Module Function Description

8.1 Block Diagram.

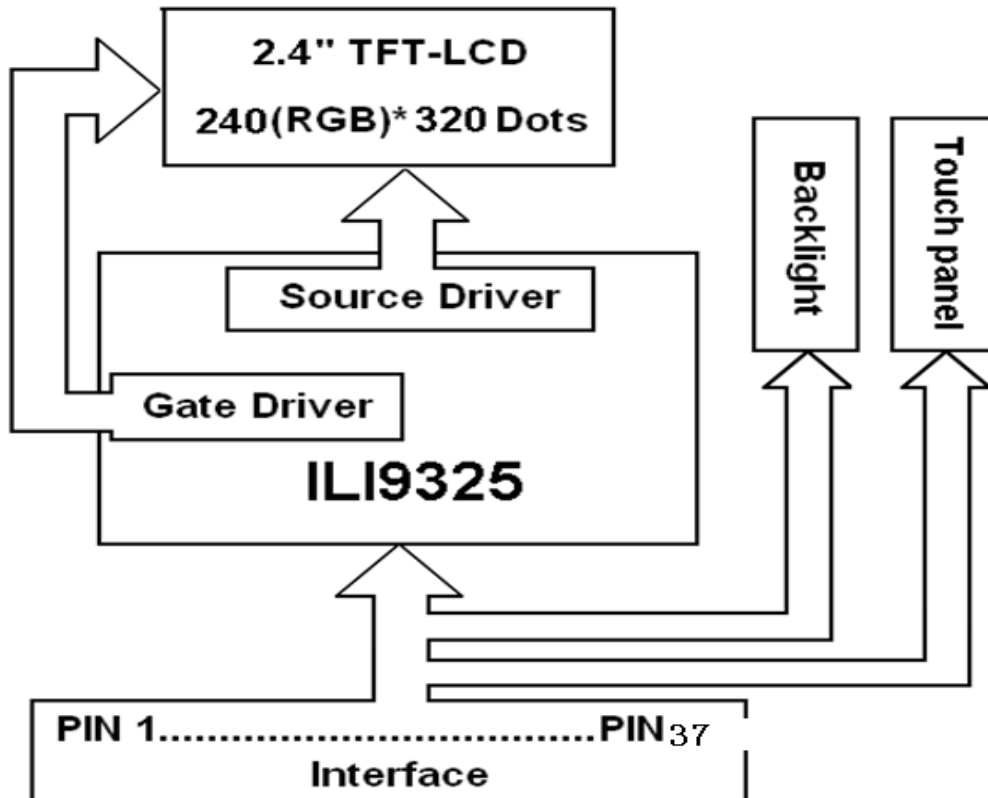

8.2 Pin Description

No.	SYMBOL	FUNCTION
1	DB0	16-bit bi-direction parallel data bus higher 8 bits.
2	DB1	
3	DB2	
4	DB3	
5	GND1	Power ground.
6	VCC1	
7	/CS	Chip select signal input terminal: /CS='H' : The LCM is selected and accessible;

specification approval

		/CS='L' : The LCM is not selected and not accessible.
8	RS	Display data/Command select signal input terminal: RS='L': current data on data bus is a command; RS='H': current data on data bus is display data.
9	/WR	Write control signal input terminal.
10	/RD	Read control signal input terminal.
11	IM0	Pins to select interfacing mode with MPU When: 1. IM0=IOVCC,80-system 8-bit interface; 2. IM0=GND,80-system 16-bit interface;
12	XL	Touch screen control terminals.
13	YD	
14	XR	
15	YU	
16	LED-A	Power supply for backlight anode input terminals.
17	LED-1	Power supply for backlight cathode input terminal.
18	LED-2	
19	LED-3	
20	LED-4	
21	IM3	Not connected, left open.
22	DB4	16-bit bi-direction parallel data bus higher 8 bits.
23	DB8	
24	DB9	
25	DB10	
26	DB11	
27	DB12	
28	DB13	
29	DB14	
30	DB15	
31	/RESET	Reset signal input terminal. Active at 'L'.
32	VCI	System power supply terminal. (VDD>VSS)
33	VCC2	System power supply terminal. (VDD>VSS)
34	GND	Power ground.
35	DB5	16-bit bi-direction parallel data bus higher 8 bits.
36	DB6	
37	DB7	

8.3 Timing Characteristics

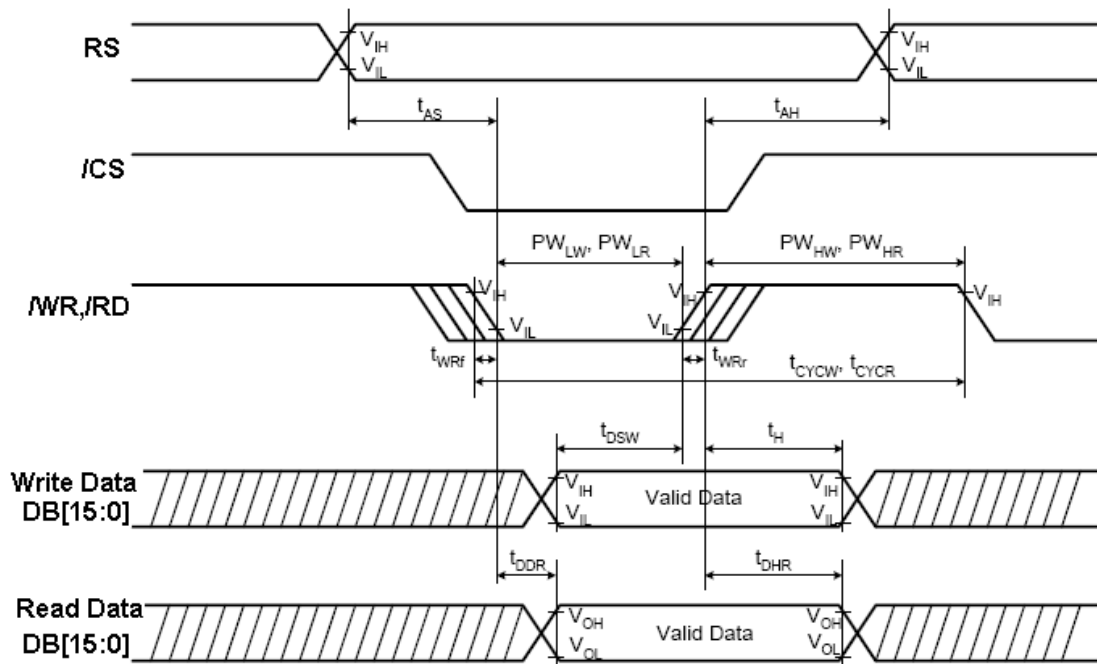

VDD=2.8V, Ta=25°C

Item	Symbol	Unit	Min.	Typ.	Max.	Test Condition
Bus cycle time	Write	t_{CYCW}	ns	100	-	-
	Read	t_{CYCR}	ns	300	-	-
Write low-level pulse width	PW_{LW}	ns	50	-	500	-
Write high-level pulse width	PW_{HW}	ns	50	-	-	-
Read low-level pulse width	PW_{LR}	ns	150	-	-	-
Read high-level pulse width	PW_{HR}	ns	150	-	-	-
Write / Read rise / fall time	t_{WRr}/t_{WRf}	ns	-	-	25	-
Setup time	Write (RS to nCS, E/nWR)	t_{AS}	ns	10	-	-
	Read (RS to nCS, RW/nRD)			5	-	-
Address hold time	t_{AH}	ns	5	-	-	-
Write data set up time	t_{DSW}	ns	10	-	-	-
Write data hold time	t_H	ns	15	-	-	-
Read data delay time	t_{DDR}	ns	-	-	100	-
Read data hold time	t_{DHR}	ns	5	-	-	-



9. Reliability Testing

No.	Test Item	Test condition	Criterion
1	High Temperature Storage	80°C±2°C 96H Restore 4H at 25°C	1. After testing, cosmetic defects should not happen. 2.Total current consumption should not be over 10% of initial value.
2	Low Temperature Storage	-30°C±2°C 96H Restore 4H at 25°C	
3	High Temperature Operation	70°C±2°C 48H Restore 4H at 25°C	
4	Low Temperature Operation	-20°C±2°C 48H Restore 4H at 25°C	
5	High Temperature /Humidity Storage	40°C±2°C 90%RH 48H	
6	Temperature Cycle	-30°C←→25°C←→80°C 5min 30min ←→25°C , 5min after 10cycle, Restore 4H at 25°C	
7	Vibration Test (package state)	10Hz~150Hz, 100m/s ² , 120min	Not allowed cosmetic and electrical defects.
8	Shock Test (package state)	Half- sine wave, 300m/s ² , 18ms	
9	Atmospheric Pressure Test	25kPa 16H Restore 2H	
10	Cable Bending Test	Bending area and angle follow design document requirement	More than 50000 times

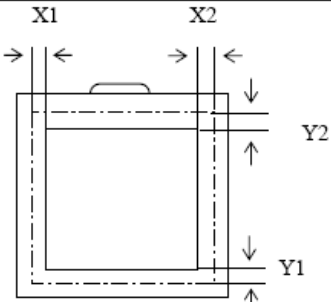
10. Quality Specification

	Note		
General	1. Should any defects which are not specified in this standard happen, additional standard shall be determined by mutual agreement between customer and Tianma. 2. Viewing Area should be the area which Tianma guarantees. 3. Limited sample should be prior to this Inspection standard. 4. Viewing Judgement should be under static pattern. 5. Inspection conditions Inspection distance : 250 mm (from the sample) Temperature : 25±5℃ Inspection angle : 45degrees in LCD view direction		
Definitions of Inspection items	Pinhole, Bright spot, Black spot, White spot, Black line, White Line, Foreign particle, Bubble	The color of a small area is different from the remainder. The phenomenon dose not change with voltage.	
	Contrast variation	The color of a small area is different from the remainder. The phenomenon changes with voltage.	
	Polarizer defect	Scratch, Dirt, Particle, Bubble on polarizer or between polarizer and glass.	
	Glass defect	Glass crack, Shaved corner of glass, Surplus glass	
Definitions of Inspection ranges	 <p style="text-align: center;">Dividing A zone and B zone proceed to make a judgment.</p> <p>A zone : Inside Viewing area B zone : Outside Viewing area X1(A.A~V.A): mm X2(A.A~V.A): mm Y1(A.A~V.A): mm Y2(A.A~V.A): mm</p>		
Outgoing Inspection standard	Inspection level II Normal Inspection Sampling standard conforms to GB2828		
	Rank	Inspection Item	AQL(Number of defective LCMs counted)
	Major defect	All Functional defects(Such as No display, Display abnormally, Open or missing segment, Short circuit, Missing component, No sound, Blight abnormally),Outline dimension beyond the drawing	0.65
Minor defect	Appearance defects, such as Black/White spot, Bright spot, Pinhole, Black/White line, Contrast variation, Bubble Glass defect, Polarizer defect, and so on. Details of the standard as follows.	1.50	

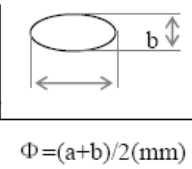
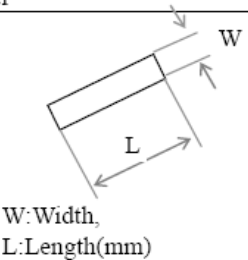
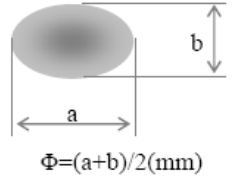
specification approval

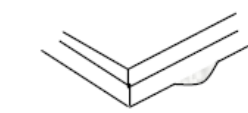
Inspection item		Judgement standard				
		Category		Acceptable number		
				A zone	B zone	
1	Black spot, White spot Bright Spot, Pinhole Foreign Particle, Bubble and Particle Between polarizer and glass, Scratch on polarizer		A	$\Phi \leq 0.15$	Neglected	Neglected
			B	$0.15 < \Phi \leq 0.20$	2	
			C	$0.20 < \Phi \leq 0.30$	1	
			D	$0.30 < \Phi$	0	
			Total defective point(B,C)		3	
2	Black line, White line, Bubble and Particle Between Polarizer and glass, Scratch on polarizer		A	$W \leq 0.10$	Neglected	Neglected
			B	$0.01 < W \leq 0.03$ $L \leq 3.0$	2	
			C	$0.03 < W \leq 0.05$ $L \leq 3.0$	1	
			D	$0.05 < W$	0	
			Total defective point(B,C)		2	
3	Contrast variation		A	$\Phi \leq 0.2$	Neglected	Neglected
			B	$0.2 < \Phi \leq 0.3$	2	
			C	$0.3 < \Phi \leq 0.4$	1	
			D	$0.4 < \Phi$	0	
			Total defective point(B,C)		3	
4	Bubble inside cell		any size		none	none
5	Polarizer defect (if Polarizer is used)	Scratch and damage on polarizer, Particle on polarizer or between polarizer and glass. Bubble, dent and convex	Refer to item 1 and item 2.			
			A	$\Phi \leq 0.3$	Neglected	Neglected
			B	$0.3 < \Phi \leq 0.7$	2	
			C	$0.7 < \Phi$	0	
			Total defective point(B,C)		2	
6	Surplus glass	①Stage surplus glass 	$b \leq 0.3\text{mm}$			
		②Surrounding surplus glass 	Should not influence outline dimension and assembling.			

Inspection item		Judgment standard									
		Category(application: B zone)									
7	Glass defect crack	①The front of lead terminals	<table border="1"> <tr> <td>A</td> <td>If $a \leq t$ and $b \leq 1.0$, c is not limited</td> </tr> <tr> <td>B</td> <td>$a \leq t$, $1 \leq b \leq 2\text{mm}$, $c \leq 3\text{mm}$</td> </tr> <tr> <td>C</td> <td>If glass crack cover alignment mark, $b \leq 0.5\text{mm}$.</td> </tr> <tr> <td>D</td> <td>Crack at two sides of lead terminals should not cover patterns and alignment mark</td> </tr> </table>	A	If $a \leq t$ and $b \leq 1.0$, c is not limited	B	$a \leq t$, $1 \leq b \leq 2\text{mm}$, $c \leq 3\text{mm}$	C	If glass crack cover alignment mark, $b \leq 0.5\text{mm}$.	D	Crack at two sides of lead terminals should not cover patterns and alignment mark
		A	If $a \leq t$ and $b \leq 1.0$, c is not limited								
		B	$a \leq t$, $1 \leq b \leq 2\text{mm}$, $c \leq 3\text{mm}$								
		C	If glass crack cover alignment mark, $b \leq 0.5\text{mm}$.								
D	Crack at two sides of lead terminals should not cover patterns and alignment mark										
②Surrounding crack—non-contact side	$b < \text{Inner border line of the seal}$										
③ Surrounding crack— contact side	$b < \text{Outer border line of the seal}$										
④Corner	<table border="1"> <tr> <td>A</td> <td>$a \leq t$, $b \leq 3.0$, $c \leq 3.0$</td> </tr> </table> <p>*Glass crack should not cover patterns used for</p>	A	$a \leq t$, $b \leq 3.0$, $c \leq 3.0$								
A	$a \leq t$, $b \leq 3.0$, $c \leq 3.0$										

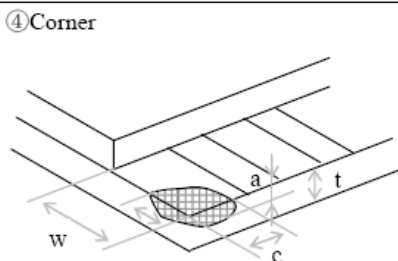
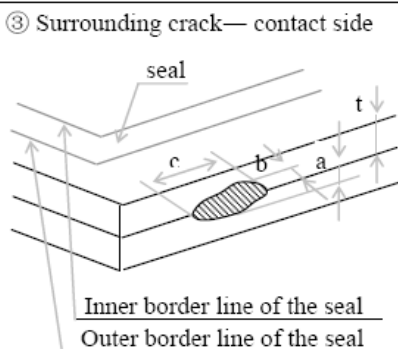
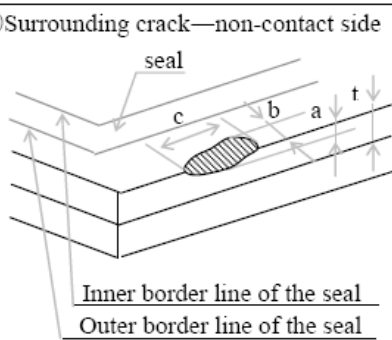
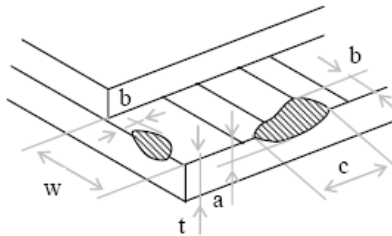

11. Precautions for Using LCD Module

11.1 Handling Precautions

- (1) The display panel is made of glass. Do not subject it to a mechanical shock or impact by dropping it.
- (2) If the display panel is damaged and the liquid crystal substance leaks out, be sure not to get any in your mouth. If the substance contacts your skin or clothes, wash it off using soap and water.
- (3) Do not apply excessive force to the display surface or the adjoining areas since this may cause the color tone to vary.
- (4) The polarizer covering the display surface of the LCD module is soft and easily scratched. Handle this polarizer carefully.
- (5) If the display surface becomes contaminated, breathe on the surface and gently wipe it with a soft dry cloth. If it is heavily contaminated, moisten a cloth with one of the following solvents:
 - Isopropyl alcohol
 - Ethyl alcohol
- (6) Solvents other than those above mentioned may damage the polarizer. Especially, do not use the following:
 - Water
 - Ketone
 - The LCD Module is coated with - Aromatic solvents
- (7) Extra care to minimize corrosion of the electrode. Water droplets, moisture condensation or a current flow in a high-humidity environment accelerates corrosion of the electrode.
- (8) Install the LCD Module by using the mounting holes. When mounting the LCD Module, make sure it is free of twisting, warping and distortion. In particular, do not forcibly pull or bend the I/O cable or the backlight cable.
- (9) Do not attempt to disassemble or process the LCD Module.
- (10) NC terminal should be open. Do not connect anything.
- (11) If the logic circuit power is off, do not apply the input signals.
- (12) To prevent destruction of the elements by static electricity, be careful to maintain an optimum work environment.
 - Be sure to ground the body when handling the LCD Module.
 - Tools required for assembling, such as soldering irons, must be properly grounded.

- To reduce the amount of static electricity generated, do not conduct assembling and other work under dry conditions.
- The LCD Module is coated with a film to protect the display surface. Exercise care when peeling off this protective film since static electricity may be generated.

11.2 Precaution For Soldering To The LCM

Observe the following when soldering lead wire, connector cable and etc. to the LCM.

- Soldering iron temperature: $280 \pm 10^{\circ}\text{C}$.
- Soldering time: 3-4 sec.
- Solder: eutectic solder.

If soldering flux is used, be sure to remove any remaining flux after finishing to soldering operation. (This does not apply in the case of a non-halogen type of flux.) It is recommended that you protect the LCD surface with a cover during soldering to prevent any damage due to flux spatters.

When soldering the electroluminescent panel and PC board, the panel and board should not be detached more than three times. This maximum number is determined by the temperature and time conditions mentioned above, though there may be some variance depending on the temperature of the soldering iron.

When removing the electroluminescent panel from the PC board, be sure the solder has completely melted, otherwise the soldered pad on the PC board could be damaged.

11.3 Precaution For Operation

- (1) Viewing angle varies with the change of liquid crystal driving voltage (V_0). Adjust V_0 to show the best contrast.
- (2) Driving the LCD in the voltage above the limit will shorten its lifetime.
- (3) Response time is greatly delayed at temperature below the operating temperature range. However, this does not mean the LCD will be out of the order. It will recover when it returns to the specified temperature range.
- (4) If the display area is pushed hard during operation, the display will become abnormal. However, it will return to normal if it is turned off and then on.
- (5) Condensation on terminals can cause an electrochemical reaction disrupting the terminal circuit. Therefore, it must be used under the relative condition of 40°C , 50% RH.
- (6) When turning the power on, input each signal after the positive/negative

voltage becomes stable.

11.4 Precaution For Storage

When storing LCDS as spares for some years, the following precaution are necessary.

Store them in a sealed polyethylene bag. If properly sealed, there is no need for desiccant.

Store them in a dark place. Do not expose to sunlight or fluorescent light, keep the temperature between 0°C and 35°C.

The polarizer surface should not come in contact with any other objects. (We advise you to store them in the container in which they were shipped.)

Environmental conditions:

- Do not leave them for more than 168hrs. at 60 °C.
- Should not be left for more than 48hrs. at -20 °C.

11.5 Safety

It is recommended to crush damaged or unnecessary LCDs into pieces and wash them off with solvents such as acetone and ethanol, which should later be burned.

If any liquid leaks out of a damaged glass cell and comes in contact with the hands, wash off thoroughly with soap and water.

11.6 Limited Warranty

Unless agreed between Matrix and customer, Matrix will replace or repair any of its LCD and modules which are found to be functionally defective when inspected in accordance with Matrix LCD acceptance standards (copies available upon request) for a period of one year from date of shipments. Cosmetic/visual defects must be returned to Matrix within 90 days of shipment. Confirmation of such date shall be based on freight documents. The warranty liability of Matrix is limited to repair and/or replacement on the terms set forth above. Matrix will not be responsible for any subsequent or consequential events.