

1. 概述

1-1 范围:

1-2 产品:

LCD 模块 (LCM)

1-3 型号:

S95300A

2. 产品特征

- (1) 显示类型: 3.2' ' TFT; Transmissive; Normally white ; 6 o' clock
- (2) 显示色彩: 65K
- (3) 背光模式: WHITE LED
- (4) 驱动 IC: HX8347-A

3. 机械规格

项目	规格	单位
外形尺寸	57.54 (W) x 79.2 (H) x 4.40(T)	mm
可视区域	48.60(W) x 64.80(H)	mm
显示内容	240RGB x 320 Dots	---
分辨率	240 x 3 x 320	Dots
像素点尺寸	67.5 (L) x 202.5 (W)	um
像素排列	STRIPE TYPE	---
结构类型	COG+FPC+BL+TP	---
背光类型	WHITE LED	—
重量		g

4. 外形尺寸

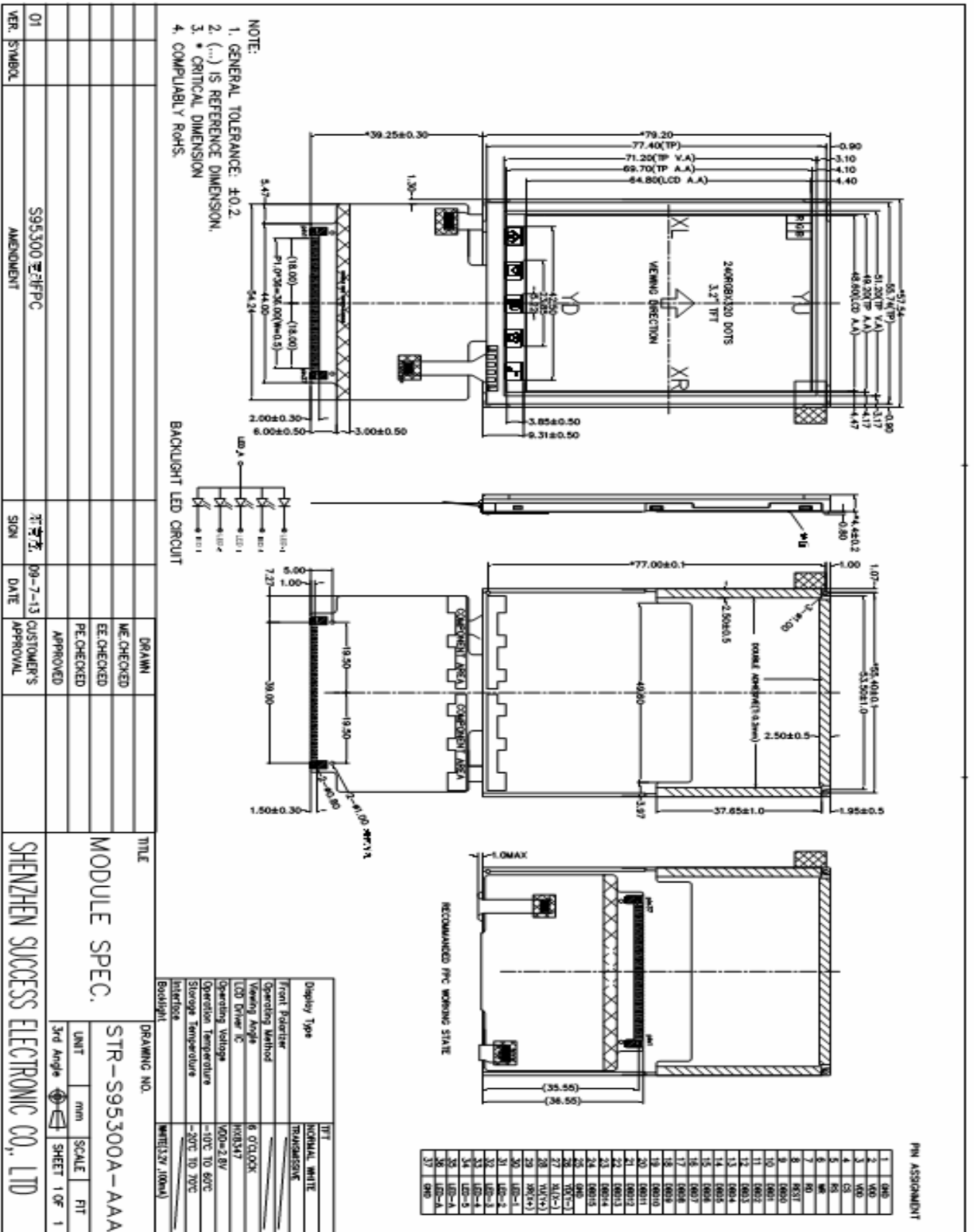

01	VER. SYMBOL	S95300 21FPC	AMENDMENT	SIGN	DATE	CUSTOMER'S APPROVAL	DRAWN	WE CHECKED	EE CHECKED	PE CHECKED	APPROVED	TITLE	MODULE SPEC.	DRAWING NO.	STR-S95300A-AAA	UNIT	mm	SCALE	FIT	SHEET	1 OF 1	3rd Angle	SHENZHEN SUCCESS ELECTRONIC CO., LTD
----	-------------	--------------	-----------	------	------	---------------------	-------	------------	------------	------------	----------	-------	--------------	-------------	-----------------	------	----	-------	-----	-------	--------	-----------	--------------------------------------

5. 接口定义

PIN NO.	FUNCTION DESCRIPTIONS	SYMBOL
1	GROUND.	GND
2	Power supply.	IOVCC
3	Power supply.	VDD
4	Chip select signal.	CS
5	COMMAND AND DATA REGISTER SELECT PIN	RS
6	WRITE SIGNAL	WR
7	READ SIGNAL	RD
8	RESET PIN.	REST
9	Data bus.	DBD0
10		DBD1
11		DBD2
12		DBD3
13		DBD4
14		DBD5
15		DBD6
16		DBD7
17		DBD8
18		DBD9
19		DBD10
20		DBD11
21		DBD12
22		DBD13
23		DBD14
24		DBD15
25	GROUND.	GND
26	TOUCH PANEL Y_DOWN	YD (Y-)
27	TOUCH PANEL X_LEFT	XL (X-)
28	TOUCH PANEL Y_UP	YU (Y+)
29	TOUCH PANEL X_RIGHT	XR (X+)
30	POWER SUPPLY- FOR BACKLIGHT CATHODE	LED-1
31	POWER SUPPLY- FOR BACKLIGHT CATHODE	LED-2
32	POWER SUPPLY- FOR BACKLIGHT CATHODE	LED-3
33	POWER SUPPLY- FOR BACKLIGHT CATHODE	LED-4
34	POWER SUPPLY- FOR BACKLIGHT CATHODE	LED-5
35	POWER SUPPLY+ FOR BACKLIGHT ANODE	LED-A
36	POWER SUPPLY+ FOR BACKLIGHT ANODE	LED-A
37	GROUND.	GND

6. 应用电路

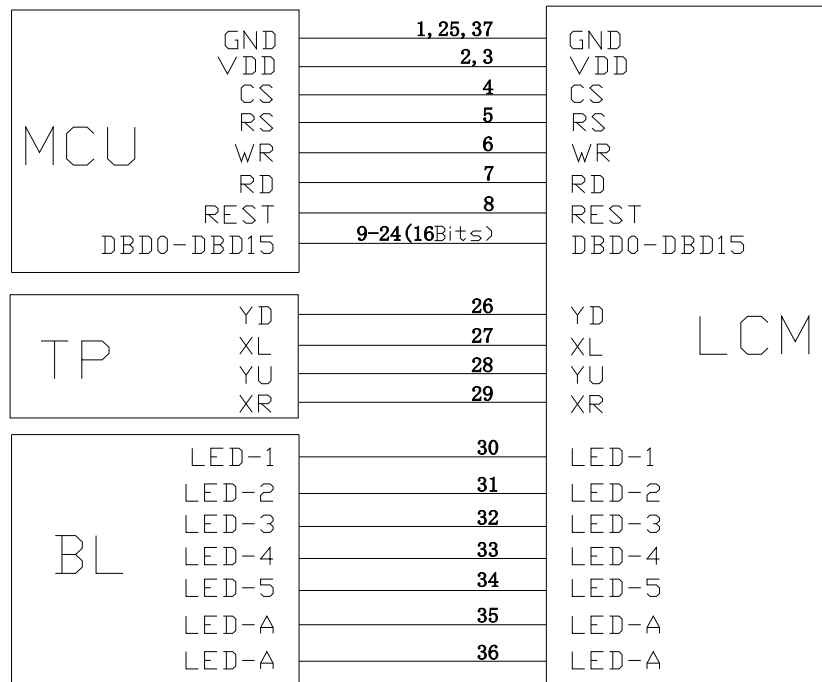

7. 功能框图

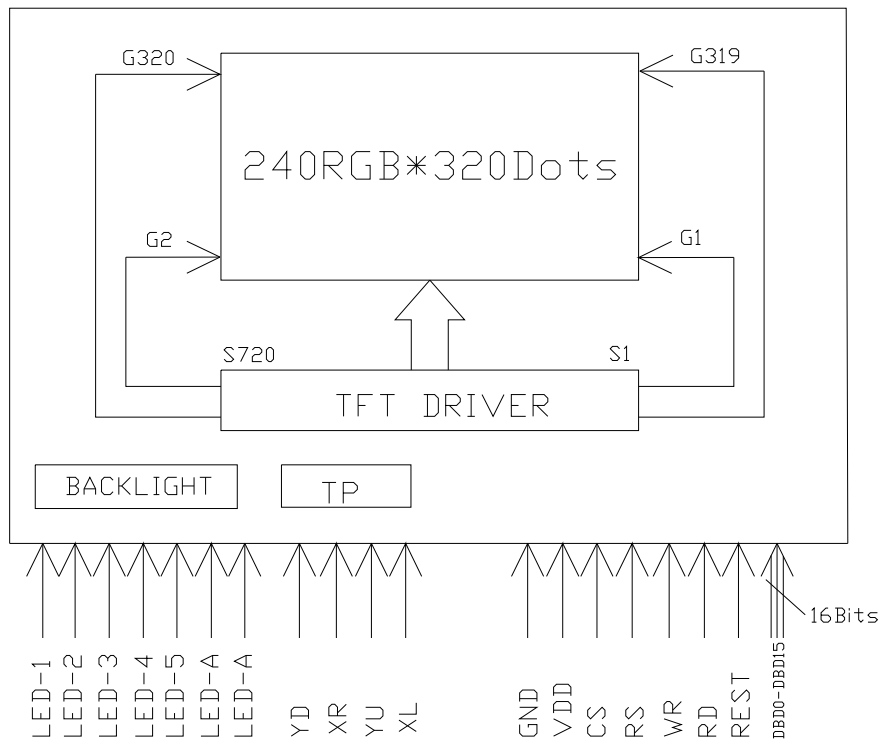

8. 接口时序

Parallel 80 接口时序

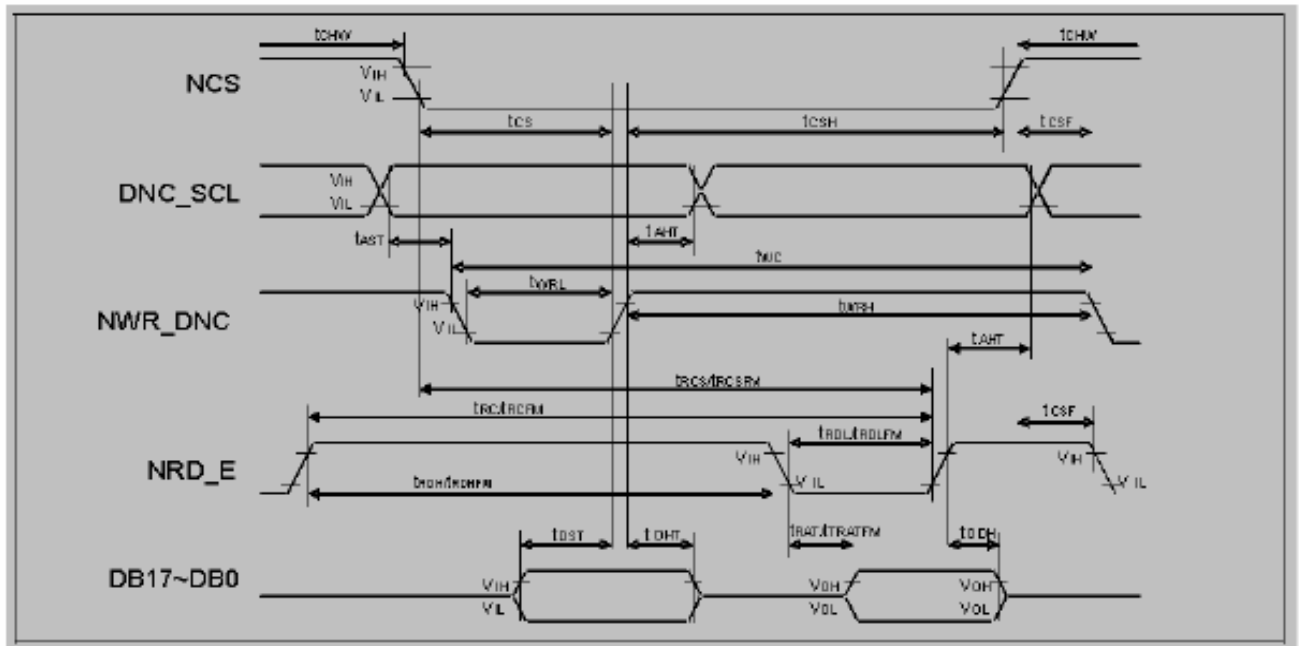

Signal	Symbol	Parameter	Min.	Max.	Unit	Description
DNC_SCL	t_{AST}	Address setup time	10	-	ns	-
	t_{AHT}	Address hold time (Write/Read)	10	-		
NCS	t_{CHW}	Chip select "H" pulse width	0	-	ns	-
	t_{CS}	Chip select setup time (Write)	35	-		
	t_{RCSFM}	Chip select setup time	355	-		
	t_{CSF}	Chip select wait time (Write/Read)	10	-		
	t_{CSH}	Chip select hold time	10	-		
NWR_RNW	t_{WC}	Write cycle	100	-	ns	-
	t_{WRH}	Control pulse "H" duration	35	-		
	t_{WRL}	Control pulse "L" duration	35	-		
NRD_E	t_{RCFM}	Read cycle	450	-	ns	When read from GRAM
	t_{RDHFM}	Control pulse "H" duration	90	-		
	t_{RDLFM}	Control pulse "L" duration	355	-		
D17 to D0	t_{DST}	Data setup time	15	-	ns	For maximum $C_L=30pF$ For minimum $C_L=8pF$
	t_{DHT}	Data hold time	10	-		
	t_{RATFM}	Read access time	-	340		
	t_{ODH}	Output disable time	20	80		

Note: The input signal rise time and fall time (t_r , t_f) is specified at 15 ns or less.

Logic high and low levels are specified as 30% and 70% of $IOVCC$ for Input signals.

($V_{SSA}=0V$, $IOVCC=1.65V$ to $2.50V$, $V_{CI}=2.3V$ to $2.9V$, $T_a = -30$ to $70^\circ C$)

9. 复位时序

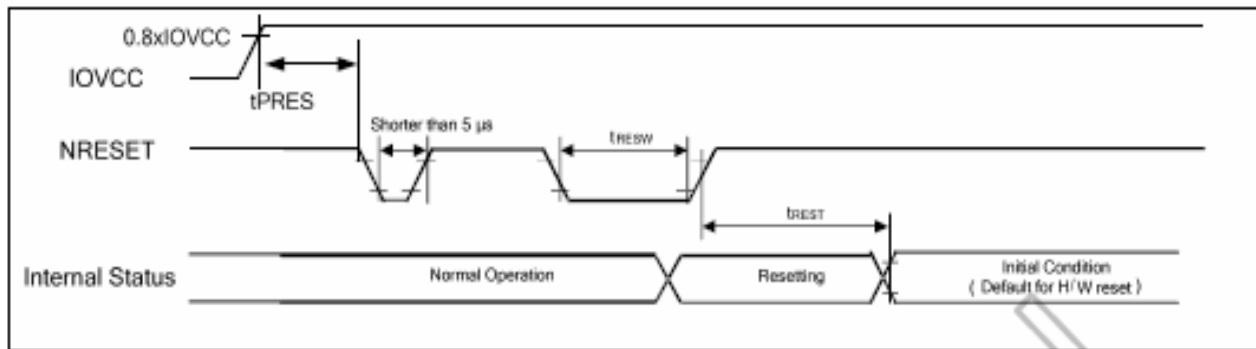

Figure 7. 1 Reset input timing

Symbol	Parameter	Related Pins	Min.	Typ.	Max.	Note	Unit
tRESW	Reset low pulse width ⁽¹⁾	NRESET	10	-	-	-	μs
tREST	Reset complete time ⁽²⁾	-	-	-	5	When reset applied during STB mode	ms
		-	-	-	120	When reset applied during STB mode	ms
tPRES	Reset goes high level after Power on time	NRESET & IOVCC	1	-	-	Reset goes high level after Power on	ms

Note: (1) Spike due to an electrostatic discharge on NRESET line does not cause irregular system reset according to the table below.

NRESET Pulse	Action
Shorter than 5 μs	Reset Rejected
Longer than 10 μs	Reset
Between 5 μs and 10 μs	Reset Start

- (2) During the resetting period, the display will be blanked (The display is entering blanking sequence, which maximum time is 120 ms, when Reset Starts in STB Out –mode. The display remains the blank state in STB –mode) and then return to Default condition for H/W reset.
- (3) During Reset Complete Time, ID2 and VCOMOF value in OTP will be latched to internal register during this period. This loading is done every time when there is H/W reset complete time (tREST) within 5ms after a rising edge of NRESET.
- (4) Spike Rejection also applies during a valid reset pulse as shown below:

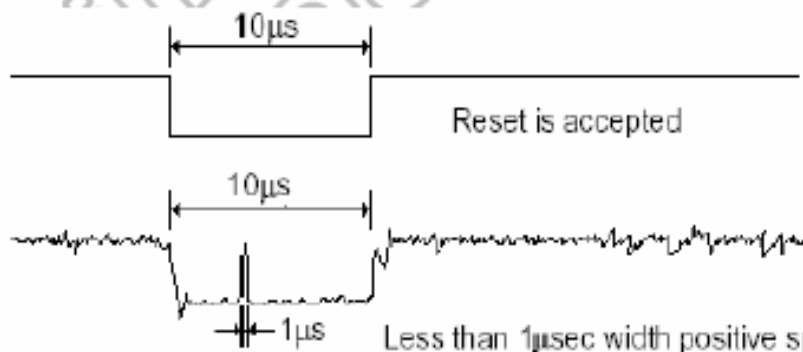

- (5) It is necessary to wait 5msec after releasing !RES before sending commands. Also STB Out command cannot be sent for 120msec.

10. DDRAM 映射表

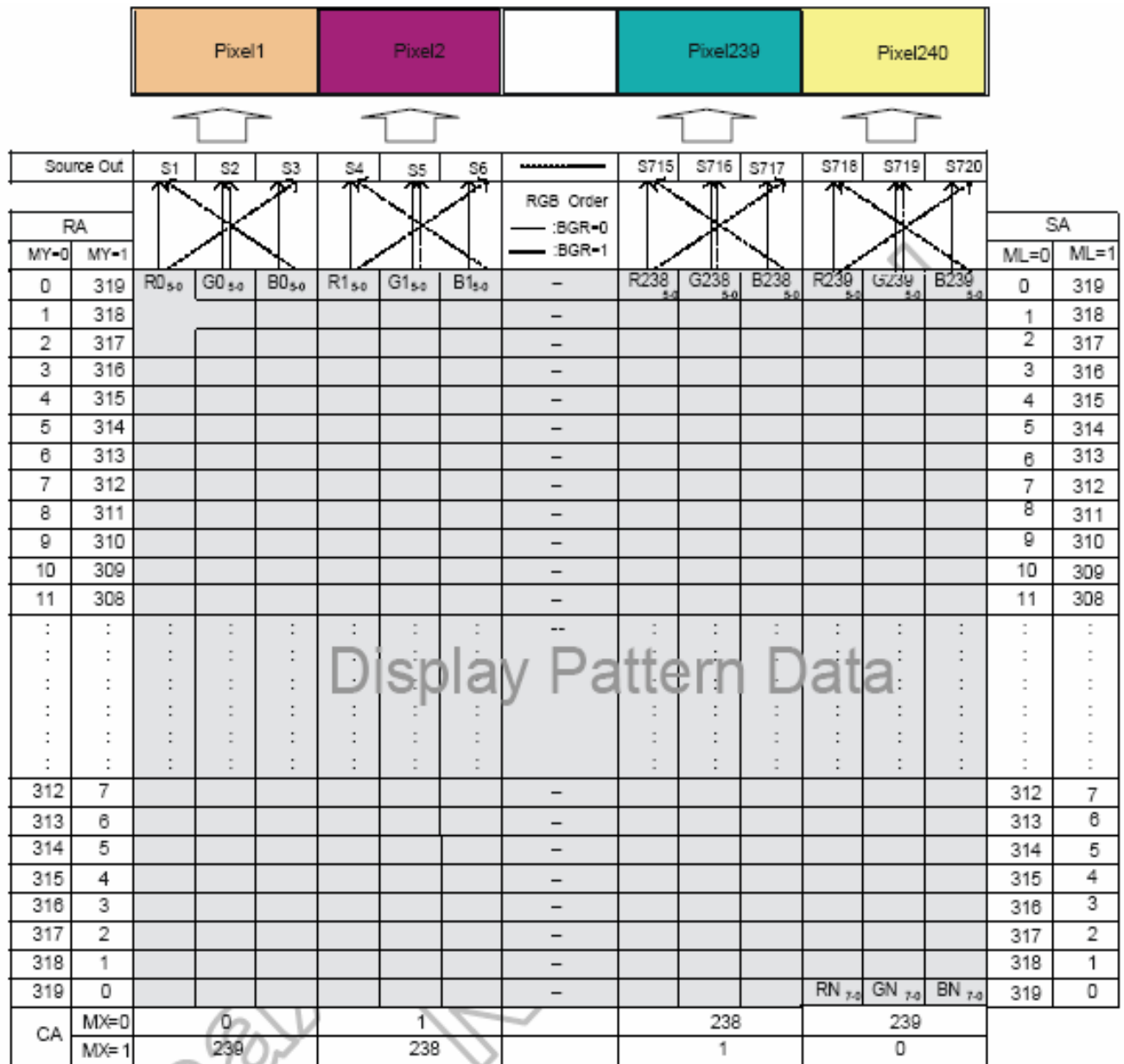

Figure 5. 23 Memory Map (240RGBx320)

NOTE: RA = Row Address,
 CA = Column Address,
 SA = Scan Address,
 MX = Mirror X-axis (Column address direction parameter), D6 parameter of Memory Access Control command
 MY = Mirror Y-axis (Row address direction parameter), D7 parameter of Memory Access Control command
 ML = Scan direction parameter, D4 parameter of Memory Access Control command
 RGB= Red, Green and Blue pixel position change, D3 parameter of Memory Access Control command

11. 极限技术参数

项目	符号	条件	标准值			单位
			最小值	典型值	最大值	
逻辑电压	VDD	Ta=25°C	-0.3	2.8	3.3	V
输入电平	VIN	Ta=25°C	-0.3	---	VDD+0.3	V
使用温度	TOPR	---	-10	---	+60	°C
存储温度	TSTG	---	-20	---	+70	°C

12. 电气参数

项目	符号	条件	标准值			单位
			最小值	典型值	最大值	
逻辑电压	VDD	Ta= +25°C	---	2.8	---	V
输入高电平	VIH	---	0.8VDD	---	VDD	V
输入低电平	VIL	---	-0.3	---	0.2VDD	V
输出高电平	VOH	IOH=-0.1mA	0.8VDD	---	---	V
输出低电平	VOL	IOL=0.1mA	---	---	0.2VDD	V

13. 背光参数

13-1 背光供电方式

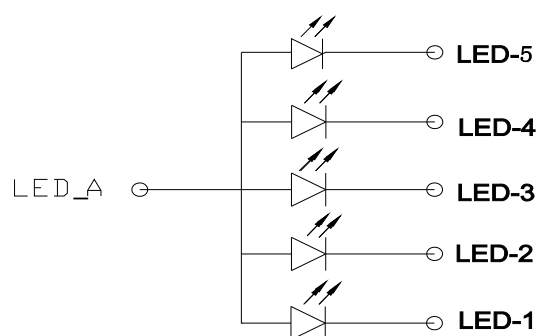

13-2 极限参数值

参数	符号	规格	单位
功耗	PD	550	mW
顺向电流	IFm	150	mA
反向电压	VR	5 (每粒灯)	V
操作温度	TOPR	-10℃ ~+60℃	℃
储存温度	TSTG	-20℃ ~+70℃	℃

13-3 电气参数

参数	符号	光源	条件	标准值			单位
				最小值	典型值	最大值	
驱动电压	Vf	WHITE	If =100mA	3.0	3.2	3.4	V
LCM亮度	Iv	WHITE		110	130	150	cd/m ²
色坐标	X	WHITE	If =100mA	0.25	—	0.29	—
	Y			0.25	—	0.29	—

14. 光电参数

Item	Symbol	Conditions	Specifications			Unit	Note	
			Min.	Typ.	Max.			
Transmittance	T%	Viewing normal angle $\theta_x = \theta_y = 0^\circ$		7.4		%	All left side data are based on CMO's following condition – Type 766 NTSC: 60% LC:5091 Light : C light (Machine:BM5A) Normal Polarizer Without DBEF	
Contrast Ratio	CR		150	250	-	-		
Response Time	T_R		NA	15	30	ms		
	T_F		NA	35	50	ms		
Chromaticity	Red		X_R	0.606	0.636	0.666		
			Y_R	0.298	0.328	0.358		
	Green		X_G	0.270	0.300	0.330		
			Y_G	0.549	0.579	0.609		
	Blue		X_B	0.102	0.132	0.162		
			Y_B	0.107	0.137	0.167		
White	X_W	0.272	0.302	0.332				
	Y_W	0.316	0.346	0.376				
Viewing Angle	Hor.	θ_{x+}		45	-	deg.		
		θ_{x-}		45	-			
	Ver.	θ_{y+}		35	-			
		θ_{y-}		15	-			

*Note (1) Definition of Contrast Ratio (CR):

The contrast ratio can be calculated by the following expression.

$$\text{Contrast Ratio (CR)} = L_{63} / L_0$$

L63: Luminance of gray level 63

L0: Luminance of gray level 0

$$CR = CR(10)$$

CR (X) is corresponding to the Contrast Ratio of the point X at Figure in Note (6).

*Note (2) Definition of Response Time (T_R , T_F):

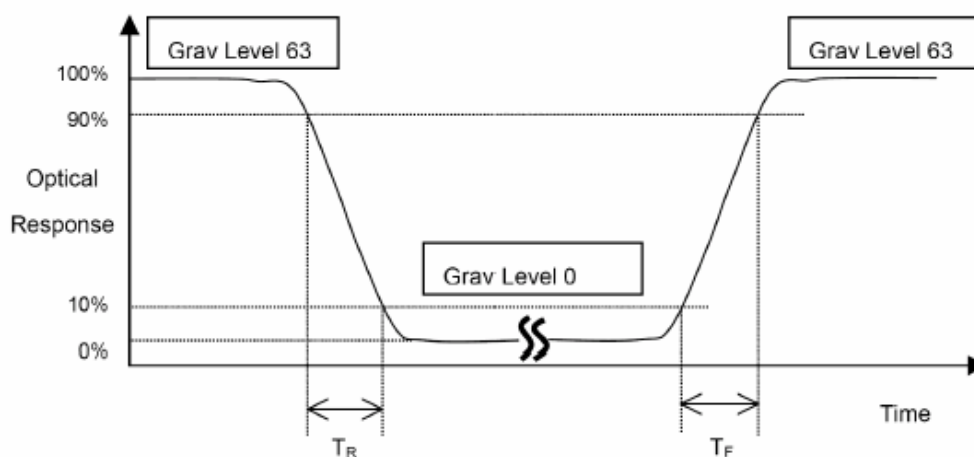

***Note(3) Definition of Viewing Angle**

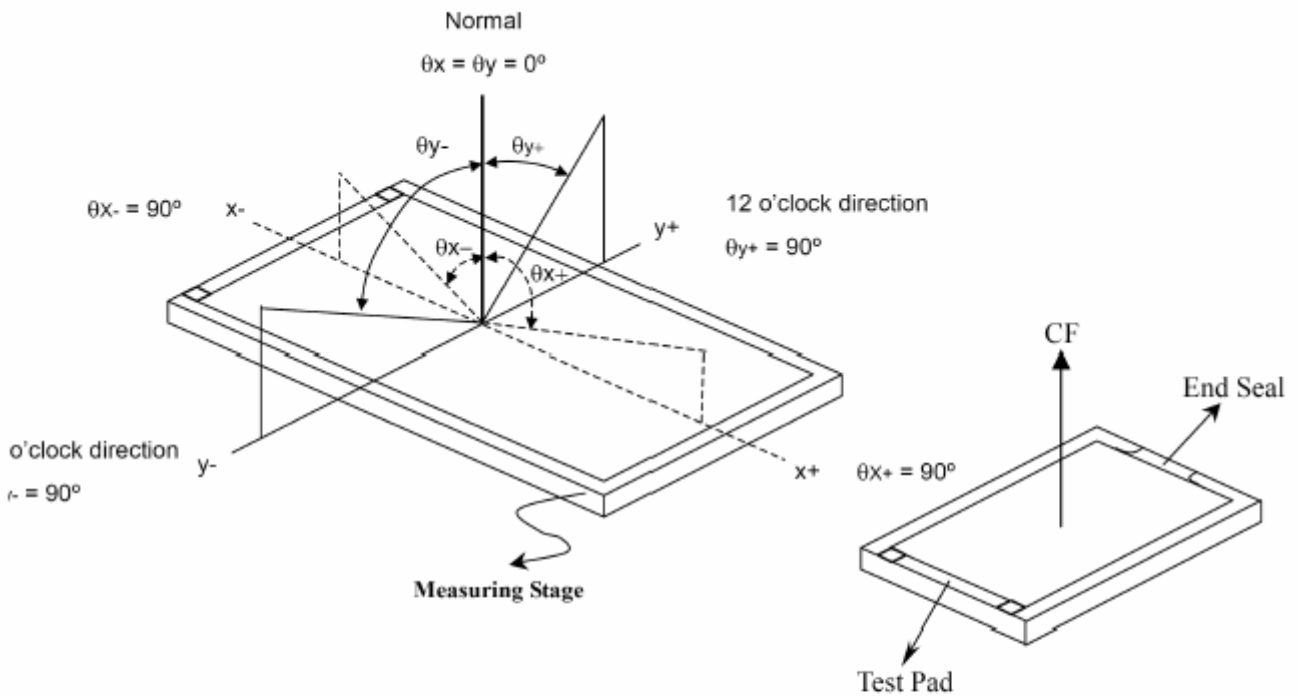

*** The above "Viewing Angle" is the measuring position with Largest Contrast Ratio; not for good image quality. View Direction for good image quality is 6 O'clock. Module maker can increase the "Viewing Angle" by applying Wide View Film.

***Note (4) Measurement Set-Up:**

The LCD module should be stabilized at a given temperature for 20 minutes to avoid abrupt temperature change during measuring. In order to stabilize the luminance, the measurement should be executed after lighting Backlight for 20 minutes in a windless room.

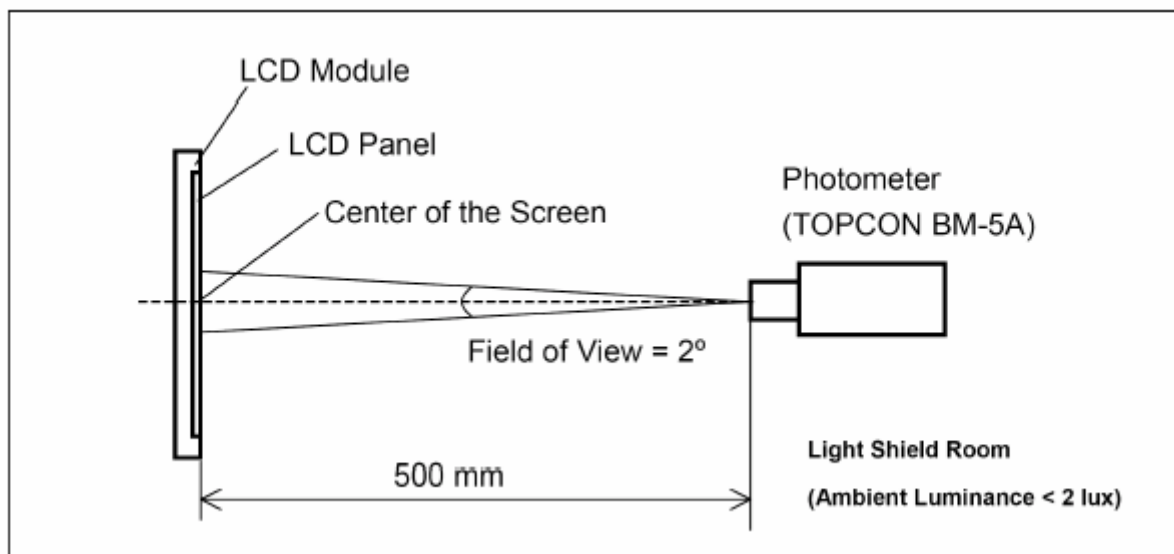

*Note (5)

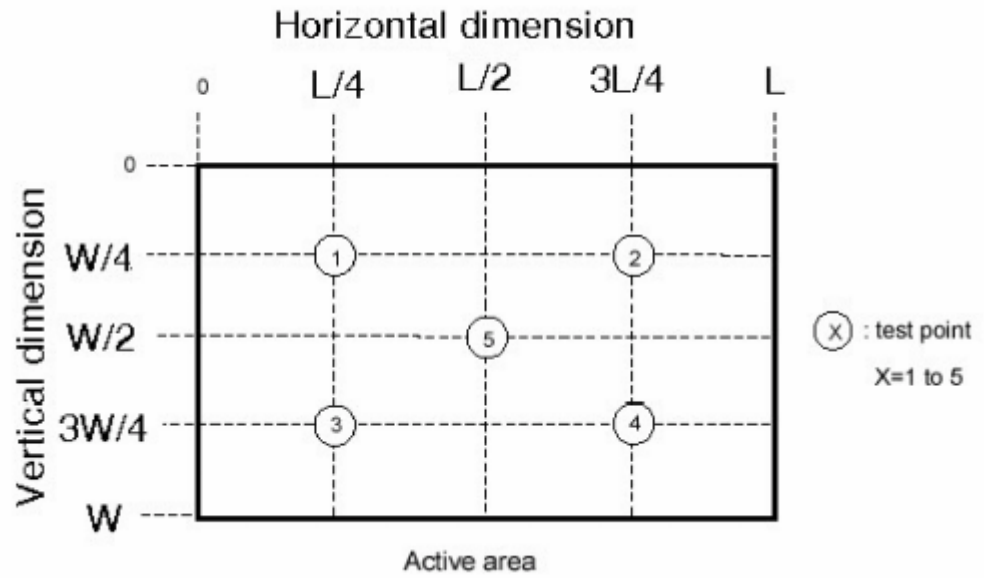

15. 极限环境参数

项目	符号	条件	标准
操作温度	TOPR	-10°C~+60°C	外观无缺陷, 功能正常
储存温度	TSTG	-20°C~+70°C	外观无缺陷, 功能正常
湿度	—	See Note	无缩合, 凝聚现象

NOTE: 测试条件

- (1) 温度和湿度: 25±2 °C, 60±5%RH (特殊条件除外)
- (2) 操作状态: 样品在正常工作时测试

16. 可靠性测试

项目	条件	标准
操作温度	高温 +60°C 72 小时	外观无缺陷, 功能正常
	低温 -10°C 72 小时	

储存温度	高温 +70°C 72 小时	外观无缺陷, 功能正常
	低温 -20°C 72 小时	
恒温恒湿	50°C 90%RH 72HRS	外观无缺陷, 功能正常
振动	时间: 每个方向振动三十分钟 (X, Y, Z) 频率: 10~55Hz (1 min) 振幅: 1.5mm	外观无缺陷, 功能正常
冷热冲击	-20°C (30mins) ←5°C (5mins) →+60°C (30mins) 10 cycles	外观无缺陷, 功能正常

NOTE: 以上测试后须在室温放置 2 小时检查样品

17. LCM 检验标准

(1) 外观检验项目及标准 (非工作状态)

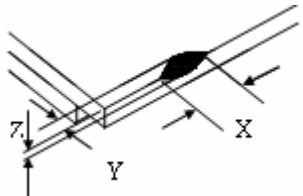
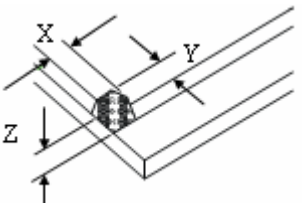
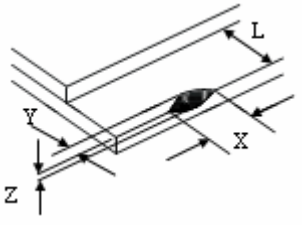
次序	项目	判断标准	AQL																						
1	尺寸状况	尺寸超出产品规格	1																						
2	缺口	<p>1、一般缺口</p>  <table border="1" style="margin-left: 20px;"> <tr> <td>X</td> <td>Y</td> <td>Z</td> </tr> <tr> <td>$\geq K/8$</td> <td>不进入 A 区</td> <td>$\leq T$</td> </tr> </table> <p>2、角缺</p>  <table border="1" style="margin-left: 20px;"> <tr> <td>X</td> <td>Y</td> <td>Z</td> </tr> <tr> <td>$\geq K/8$</td> <td>不进入 A 区</td> <td>不计</td> </tr> </table> <p>3、引脚部位缺口</p>  <table border="1" style="margin-left: 20px;"> <tr> <td>X</td> <td>Y</td> <td>Z</td> </tr> <tr> <td>$\geq K/8$</td> <td>$\geq L/3$</td> <td>不计</td> </tr> </table> <p>4、边缘突起</p> <table border="1" style="margin-left: 20px;"> <tr> <td>X</td> <td>Y</td> </tr> <tr> <td>$\geq K/8$</td> <td>$\geq L/3$</td> </tr> </table>	X	Y	Z	$\geq K/8$	不进入 A 区	$\leq T$	X	Y	Z	$\geq K/8$	不进入 A 区	不计	X	Y	Z	$\geq K/8$	$\geq L/3$	不计	X	Y	$\geq K/8$	$\geq L/3$	2.50
X	Y	Z																							
$\geq K/8$	不进入 A 区	$\leq T$																							
X	Y	Z																							
$\geq K/8$	不进入 A 区	不计																							
X	Y	Z																							
$\geq K/8$	$\geq L/3$	不计																							
X	Y																								
$\geq K/8$	$\geq L/3$																								

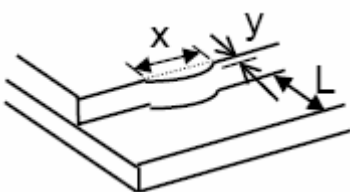
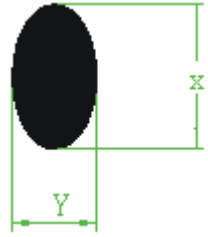
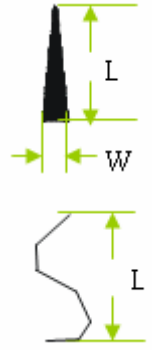
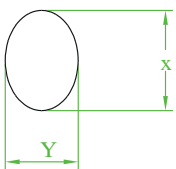
		 <p>缺口伤及线路斑马纸产品 $Y \leq L/5$；导电胶条产品 $Y \leq L/3$；装脚产品 $Y \leq 0.3\text{mm}$ 判断</p>																				
3	点状缺陷	 <table border="1" data-bbox="821 526 1412 795"> <thead> <tr> <th rowspan="2">D</th> <th colspan="2">允许缺陷数</th> </tr> <tr> <th>A/B 区</th> <th>C 区</th> </tr> </thead> <tbody> <tr> <td>$D < 0.2$</td> <td>不限</td> <td rowspan="4">不限</td> </tr> <tr> <td>$0.2 \leq D < 0.3$</td> <td>2</td> </tr> <tr> <td>$0.3 \leq D \leq 0.5$</td> <td>1</td> </tr> <tr> <td>$D > 0.5$</td> <td>0</td> </tr> </tbody> </table> <p>X:长径 Y:短径 D:平均直径 $D = (X+Y)/2$</p>	D	允许缺陷数		A/B 区	C 区	$D < 0.2$	不限	不限	$0.2 \leq D < 0.3$	2	$0.3 \leq D \leq 0.5$	1	$D > 0.5$	0	2.50					
D	允许缺陷数																					
	A/B 区	C 区																				
$D < 0.2$	不限	不限																				
$0.2 \leq D < 0.3$	2																					
$0.3 \leq D \leq 0.5$	1																					
$D > 0.5$	0																					
4	线状缺陷	 <table border="1" data-bbox="774 985 1412 1254"> <thead> <tr> <th rowspan="2">长度</th> <th rowspan="2">宽度</th> <th colspan="2">允许缺陷数</th> </tr> <tr> <th>A/B 区</th> <th>C 区</th> </tr> </thead> <tbody> <tr> <td>不计</td> <td>$W \leq 0.02$</td> <td>不计</td> <td rowspan="3">不限</td> </tr> <tr> <td>$L \leq 3$</td> <td>$W \leq 0.05$</td> <td>2</td> </tr> <tr> <td rowspan="2">$L \leq 2.5$</td> <td>$W \leq 0.05$</td> <td>2</td> </tr> <tr> <td>$W > 0.05$</td> <td colspan="2">按点状缺陷判定</td> </tr> </tbody> </table> <p>L:长度 W:宽度 对偏光片（刮伤、污点、压痕）有限度样本则以限度样本判断</p>	长度	宽度	允许缺陷数		A/B 区	C 区	不计	$W \leq 0.02$	不计	不限	$L \leq 3$	$W \leq 0.05$	2	$L \leq 2.5$	$W \leq 0.05$	2	$W > 0.05$	按点状缺陷判定		2.50
长度	宽度	允许缺陷数																				
		A/B 区	C 区																			
不计	$W \leq 0.02$	不计	不限																			
$L \leq 3$	$W \leq 0.05$	2																				
$L \leq 2.5$	$W \leq 0.05$	2																				
	$W > 0.05$	按点状缺陷判定																				
5	偏光片 气泡/水纹/皱纹	 <table border="1" data-bbox="790 1456 1412 1724"> <thead> <tr> <th rowspan="2">D</th> <th colspan="2">允许缺陷数</th> </tr> <tr> <th>A/B 区</th> <th>C 区</th> </tr> </thead> <tbody> <tr> <td>$D \leq 0.2$</td> <td>不限</td> <td rowspan="4">不限</td> </tr> <tr> <td>$0.2 \leq D \leq 0.5$</td> <td>3 个</td> </tr> <tr> <td>$0.5 \leq D \leq 1.0$</td> <td>2 个</td> </tr> <tr> <td>$D > 1.0$</td> <td>0 个</td> </tr> </tbody> </table>	D	允许缺陷数		A/B 区	C 区	$D \leq 0.2$	不限	不限	$0.2 \leq D \leq 0.5$	3 个	$0.5 \leq D \leq 1.0$	2 个	$D > 1.0$	0 个	2.50					
D	允许缺陷数																					
	A/B 区	C 区																				
$D \leq 0.2$	不限	不限																				
$0.2 \leq D \leq 0.5$	3 个																					
$0.5 \leq D \leq 1.0$	2 个																					
$D > 1.0$	0 个																					
6	外丝印	<ol style="list-style-type: none"> 1、丝印变形、针孔：按照字符变形针孔规格判断。 2、丝印宽度：丝印宽度 $\geq 1/2$ 标准宽度，可判 OK。 	2.50																			
7	打胶（硅胶）	打胶面积必须盖住 ITO 引线	2.50																			
8	PCB 板不良	<ol style="list-style-type: none"> 1、PCB 板烧焦、版本不符、线路剥离、裂痕、导电过孔堵不允许 2、PCB 板金手指不可有氧化、腐蚀、胶状物、断裂现象 	2.50																			
9	贴片元件	1、元件装配上下、左右偏位 $\leq 1/3$ 元件本体宽度	2.50																			

		2、焊锡点尽可能光滑圆润 3、元件受损、破裂、少件、多件、元件装配反向、漏焊不允许	
10	铁框	破裂、变形不允许 外形尺寸参照产品规格书	2.50

(2) 显示功能检验项目及标准 (工作状态)

1	电性能缺陷	断路	不允许		1.0														
		短路/大电流	不允许																
		视角错误	不允许																
2	字划 凸起/缺口	1、针孔缺口	<table border="1"> <thead> <tr> <th>宽度</th> <th>接收规格</th> </tr> </thead> <tbody> <tr> <td>$W < 0.4$</td> <td>$D \leq 0.2$ & $D \leq 1/2W$</td> </tr> <tr> <td>$W \geq 0.4$</td> <td>$D \leq 0.25$ & $D \leq 1/3W$</td> </tr> </tbody> </table>		宽度	接收规格	$W < 0.4$	$D \leq 0.2$ & $D \leq 1/2W$	$W \geq 0.4$	$D \leq 0.25$ & $D \leq 1/3W$	2.50								
		宽度	接收规格																
$W < 0.4$	$D \leq 0.2$ & $D \leq 1/2W$																		
$W \geq 0.4$	$D \leq 0.25$ & $D \leq 1/3W$																		
 <p>* $D = (A+B)/2$ $D \leq 0.1$ 则忽略不计</p>																			
3	字划/图案 粗细		<table border="1"> <thead> <tr> <th>宽度</th> <th>接收规格</th> </tr> </thead> <tbody> <tr> <td>$W < 0.4$</td> <td>$C、D、G \leq 1/2W$</td> </tr> <tr> <td>$W \geq 0.4$</td> <td>$C、D、G \leq 0.2$</td> </tr> </tbody> </table>		宽度	接收规格	$W < 0.4$	$C、D、G \leq 1/2W$	$W \geq 0.4$	$C、D、G \leq 0.2$	1.0								
		宽度	接收规格																
$W < 0.4$	$C、D、G \leq 1/2W$																		
$W \geq 0.4$	$C、D、G \leq 0.2$																		
<p>W: 图案设计尺寸 C、D: 差异尺寸 $G = E-F$</p>																			
4	点状缺陷		<table border="1"> <thead> <tr> <th rowspan="2">D</th> <th colspan="2">允许缺陷数</th> </tr> <tr> <th>A/B 区</th> <th>C 区</th> </tr> </thead> <tbody> <tr> <td>$D < 0.1$</td> <td>不限</td> <td rowspan="4">不限</td> </tr> <tr> <td>$0.1 \leq D < 0.2$</td> <td>2</td> </tr> <tr> <td>$0.2 \leq D \leq 0.25$</td> <td>1</td> </tr> <tr> <td>$D > 0.25$</td> <td>0</td> </tr> </tbody> </table>		D	允许缺陷数		A/B 区	C 区	$D < 0.1$	不限	不限	$0.1 \leq D < 0.2$	2	$0.2 \leq D \leq 0.25$	1	$D > 0.25$	0	2.50
		D	允许缺陷数																
A/B 区	C 区																		
$D < 0.1$	不限	不限																	
$0.1 \leq D < 0.2$	2																		
$0.2 \leq D \leq 0.25$	1																		
$D > 0.25$	0																		
<p>X: 长径 Y: 短径 D: 平均直径 $D = (X+Y)/2$ 如黑点、污迹在字段区, 按“笔段缺陷”判定</p>																			

5	线状缺陷	 <p>L:长度 W:宽度</p> <table border="1" data-bbox="774 280 1412 324"> <tr> <td>长度</td> <td>宽度</td> <td>允许缺陷数</td> </tr> </table>	长度	宽度	允许缺陷数	2.50
长度	宽度	允许缺陷数				