

REV.	MATTER	APP.	DATE
A			

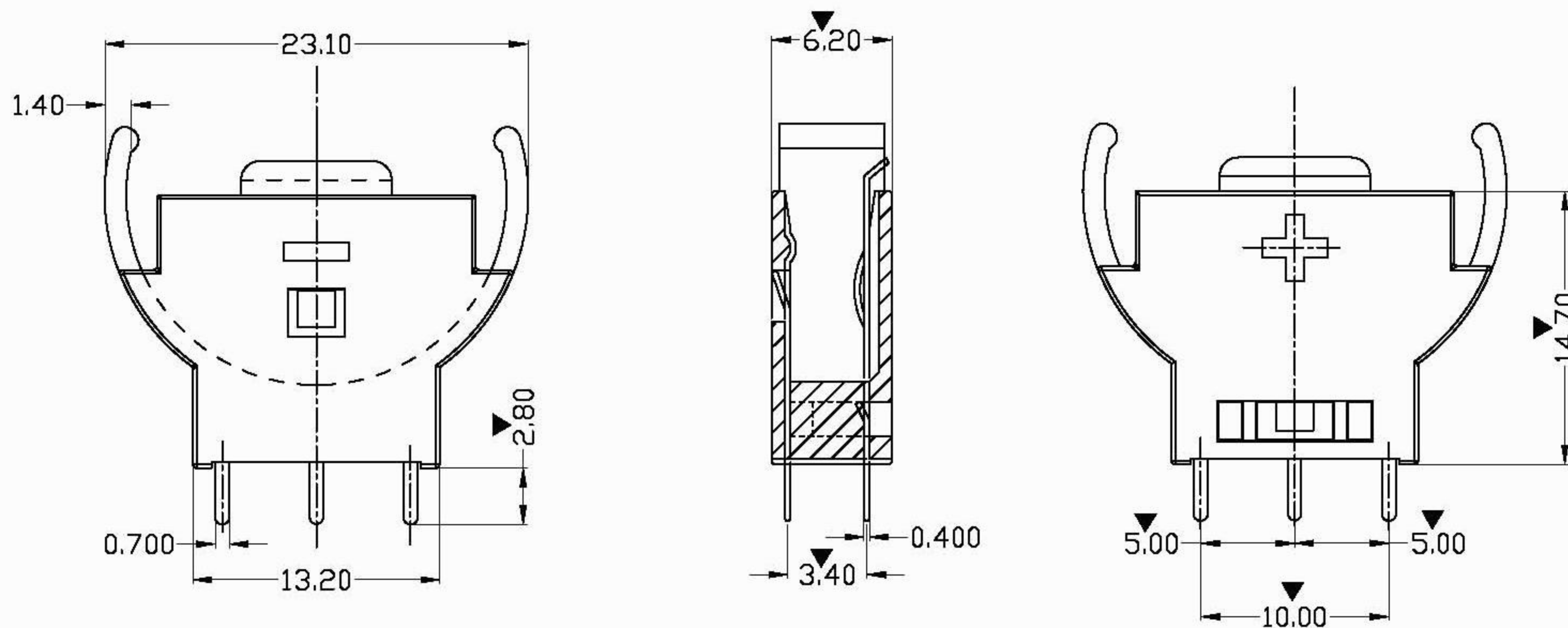

NOTE:
 1.MATERIAL:
 a.HOUSING:THERMOPLASTIC GLASS FIBRE UL94V-0
 b.CONTACT:BRASS
 (SURFACE PLATING: Sn100u")
 SEE ORDERING INFORMATION
 2.ELECTRIC:
 a.CONTACT RESISTANCE: 30 MILLIOHMS MAX
 b.INSULATION RESISTANCE: 1000 MEGA OHMS MIN
 c.DIELECTNIC VOLTAGE: 750V AC ONE SEC LEVEL
 d.OPERATING TEMPERATURE: -55° C~ +85° C

ORDERING INFORMATION

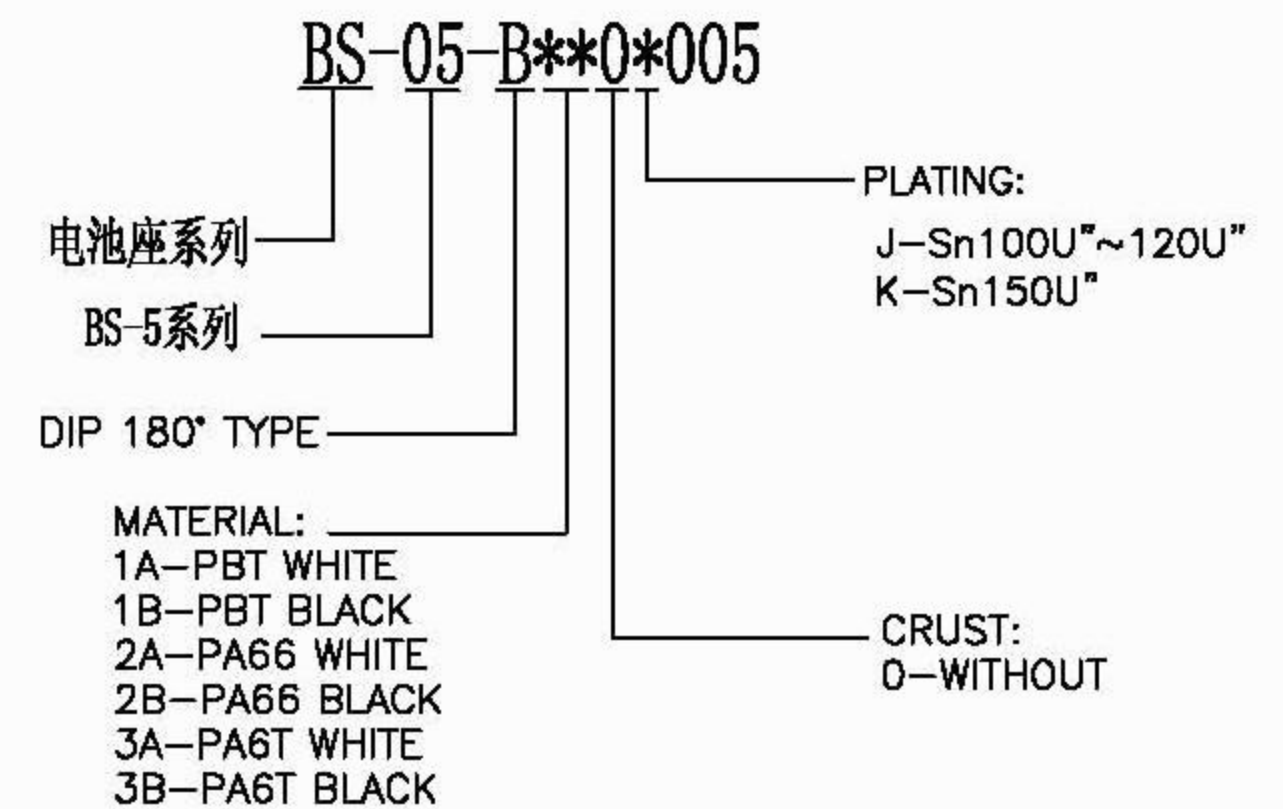

注 ▼为重点管控尺寸

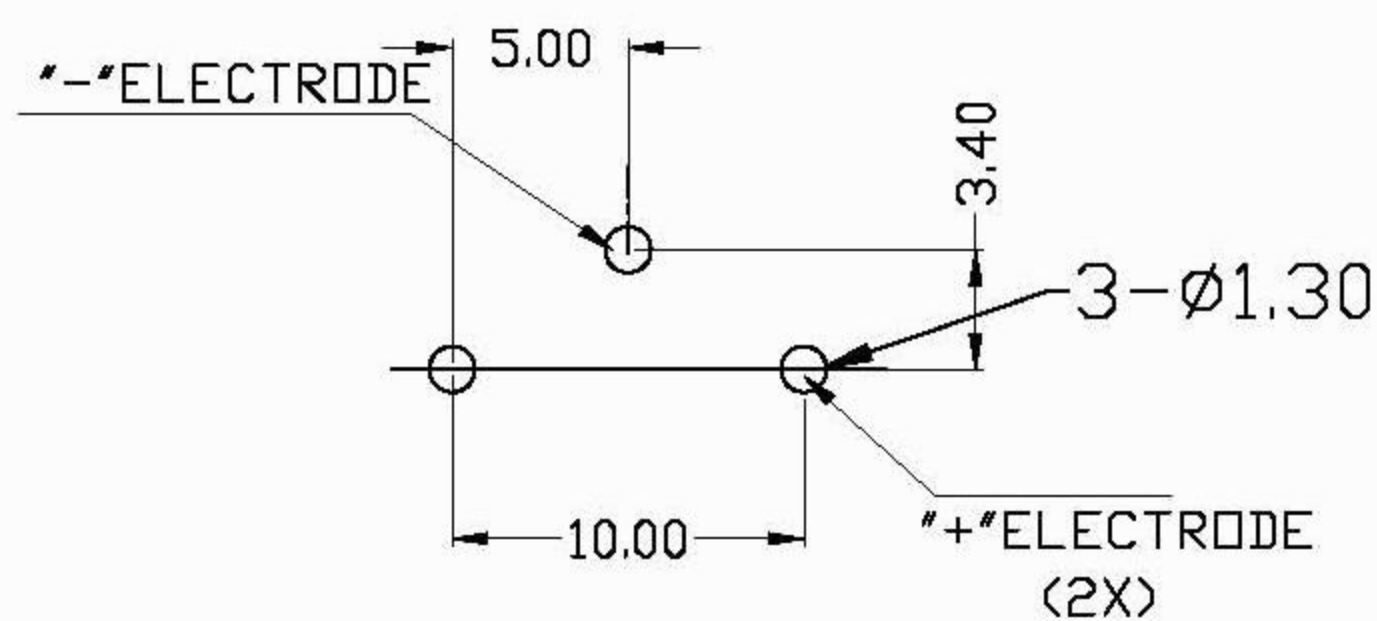

PCB LAYOUT

深圳市迈洛克实业有限公司

TOLERANCE		DRAWN	UNIT: MM	TITLE: 三PIN电池座立式 (BS-5)	
LINEAR	ANGLE			APPROVED	SCALE: 1/1
x. ±1	x.° ±5°	DATE 2008.06.10	SIZE: A4	DWG. NO. BS-05	SHEET. 1 OF 1
.x ±0.38	.x' ±2°				
.xx ±0.25	.xx' ±1°				
.xxx ±0.10					