

アルミニウム電解コンデンサ ALUMINUM ELECTROLYTIC CAPACITORS

GG 基板自立形・105°C超小形品

シリーズ



- GNシリーズの小形化品。
- 機器の小形化に寄与。
- RoHS指令 (2011/65/EU) 対応済。

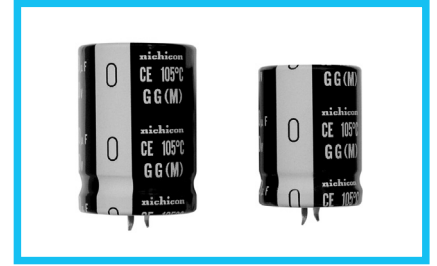

スリーブ色：ブラック

仕様

項目	性能			
カテゴリ温度範囲	-40~+105°C (160~250V)、-25~+105°C (400~450V)			
定格電圧範囲	160~450V			
定格静電容量範囲	100~3300μF			
定格静電容量許容差	±20% (120Hz, 20°C)			
漏れ電流	3√CV (μA) 以下 (5分値) [C: 定格静電容量 (μF), V: 定格電圧 (V)]			
損失角の正接 (tan δ)	定格電圧 (V)	160~420	450	120Hz 20°C
	tan δ (MAX.)	0.15	0.20	
温度特性	定格電圧 (V)	160~250	400~450	120Hz
	インピーダンス比 (MAX.) Z-25°C / Z+20°C	4	8	
耐久性	105°C 2000時間 定格電圧をこえない範囲で規定の定格リプル電流を重畳印加後、20°Cに戻し測定を行ったとき、下記項目を満足する			
	静電容量変化率	初期値の±20%以内		
	tan δ	初期規格値の200%以下		
	漏れ電流	初期規格値以下		
高温無負荷特性	105°C 1000時間 無負荷放置後、20°CにてJIS C 5101-4 4.1項による電圧処理を行った後、下記項目を満足する			
	静電容量変化率	初期値の±20%以内		
	tan δ	初期規格値の200%以下		
	漏れ電流	初期規格値以下		
表示	ブラックスリーブに白色表示			

寸法図

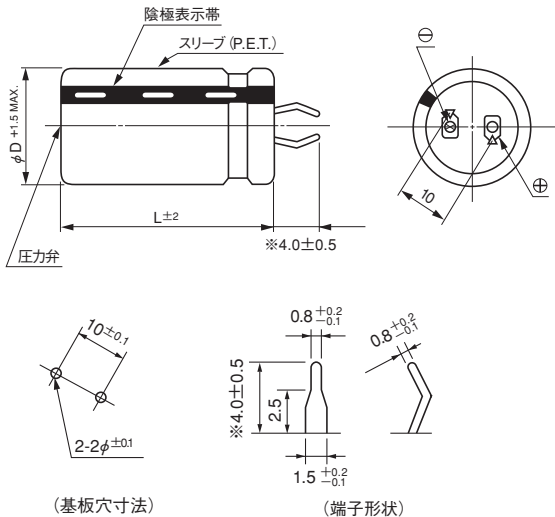

※その他端子形状にても製作致します。
313頁の端子形状の頁をご参照ください。

品番コード体系 (例: 400V 180μF)

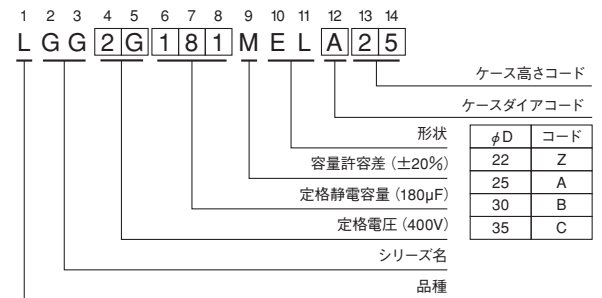

・最小受注単位：50個

●寸法表は次頁に掲載しております。

アルミニウム電解コンデンサ ALUMINUM ELECTROLYTIC CAPACITORS



■寸法表

160V (2C)				
定格静電容量 (μ F)	サイズ ϕ DXL (mm)	リップル (mA)	漏れ電流 (mA)	品番
560	22 × 25	1400	0.89	LGG2C561MELZ25
680	22 × 30	1500	0.98	LGG2C681MELZ30
	25 × 25	1700	0.98	LGG2C681MELA25
820	22 × 35	2000	1.08	LGG2C821MELZ35
	25 × 30	2000	1.08	LGG2C821MELA30
1000	22 × 40	2100	1.20	LGG2C102MELZ40
	25 × 35	2200	1.20	LGG2C102MELA35
	30 × 25	2200	1.20	LGG2C102MELB25
1200	25 × 40	2300	1.31	LGG2C122MELA40
	30 × 30	2300	1.31	LGG2C122MELB30
	35 × 25	2300	1.31	LGG2C122MELC25
1500	25 × 45	2500	1.46	LGG2C152MELA45
	30 × 35	2500	1.46	LGG2C152MELB35
	35 × 30	2500	1.46	LGG2C152MELC30
1800	30 × 40	2700	1.60	LGG2C182MELB40
	35 × 30	2550	1.60	LGG2C182MELC30
2200	30 × 45	2900	1.77	LGG2C222MELB45
	35 × 35	2900	1.77	LGG2C222MELC35
2700	35 × 40	3000	1.97	LGG2C272MELC40
3300	35 × 45	3100	2.17	LGG2C332MELC45

180V (2Z)				
定格静電容量 (μ F)	サイズ ϕ DXL (mm)	リップル (mA)	漏れ電流 (mA)	品番
470	22 × 25	1300	0.87	LGG2Z471MELZ25
560	22 × 30	1500	0.95	LGG2Z561MELZ30
680	22 × 35	1700	1.04	LGG2Z681MELZ35
	25 × 30	1700	1.04	LGG2Z681MELA30
820	22 × 40	2000	1.15	LGG2Z821MELZ40
	25 × 35	2000	1.15	LGG2Z821MELA35
	30 × 25	2000	1.15	LGG2Z821MELB25
1000	22 × 45	2100	1.27	LGG2Z102MELZ45
	25 × 35	2050	1.27	LGG2Z102MELA35
	30 × 30	2200	1.27	LGG2Z102MELB30
1200	22 × 50	2150	1.39	LGG2Z122MELZ50
	25 × 40	2150	1.39	LGG2Z122MELA40
	30 × 35	2300	1.39	LGG2Z122MELB35
	35 × 25	2150	1.39	LGG2Z122MELC25
1500	25 × 50	2400	1.55	LGG2Z152MELA50
	30 × 40	2500	1.55	LGG2Z152MELB40
	35 × 30	2350	1.55	LGG2Z152MELC30
1800	30 × 45	2700	1.70	LGG2Z182MELB45
	35 × 35	2700	1.70	LGG2Z182MELC35
2200	30 × 50	2900	1.88	LGG2Z222MELB50
	35 × 40	2900	1.88	LGG2Z222MELC40
2700	35 × 45	3000	2.09	LGG2Z272MELC45
3300	35 × 50	3100	2.31	LGG2Z332MELC50

200V (2D)				
定格静電容量 (μ F)	サイズ ϕ DXL (mm)	リップル (mA)	漏れ電流 (mA)	品番
470	22 × 25	1200	0.91	LGG2D471MELZ25
560	22 × 30	1480	1.00	LGG2D561MELZ30
	25 × 25	1480	1.00	LGG2D561MELA25
680	22 × 35	1600	1.10	LGG2D681MELZ35
	25 × 30	1600	1.10	LGG2D681MELA30
820	22 × 40	1750	1.21	LGG2D821MELZ40
	25 × 35	1750	1.21	LGG2D821MELA35
	30 × 25	1750	1.21	LGG2D821MELB25
1000	22 × 45	2040	1.34	LGG2D102MELZ45
	25 × 40	2040	1.34	LGG2D102MELA40
	30 × 30	2040	1.34	LGG2D102MELB30
1200	25 × 45	2300	1.46	LGG2D122MELA45
	30 × 35	2300	1.46	LGG2D122MELB35
	35 × 25	2300	1.46	LGG2D122MELC25
1500	25 × 50	2570	1.64	LGG2D152MELA50
	30 × 40	2570	1.64	LGG2D152MELB40
	35 × 30	2570	1.64	LGG2D152MELC30
1800	30 × 45	2680	1.80	LGG2D182MELB45
	35 × 35	2680	1.80	LGG2D182MELC35
2200	30 × 50	2920	1.98	LGG2D222MELB50
	35 × 40	2920	1.98	LGG2D222MELC40
2700	35 × 45	3270	2.20	LGG2D272MELC45

220V (2P)				
定格静電容量 (μ F)	サイズ ϕ DXL (mm)	リップル (mA)	漏れ電流 (mA)	品番
330	22 × 25	1260	0.80	LGG2P331MELZ25
390	22 × 30	1340	0.87	LGG2P391MELZ30
470	22 × 35	1480	0.96	LGG2P471MELZ35
	25 × 25	1400	0.96	LGG2P471MELA25
560	22 × 35	1450	1.05	LGG2P561MELZ35
	25 × 30	1450	1.05	LGG2P561MELA30
680	22 × 40	1650	1.16	LGG2P681MELZ40
	25 × 35	1780	1.16	LGG2P681MELA35
	30 × 25	1650	1.16	LGG2P681MELB25
820	22 × 50	1930	1.27	LGG2P821MELZ50
	25 × 40	1930	1.27	LGG2P821MELA40
	30 × 30	1850	1.27	LGG2P821MELB30
	35 × 25	1930	1.27	LGG2P821MELC25
1000	25 × 45	2150	1.40	LGG2P102MELA45
	30 × 35	2330	1.40	LGG2P102MELB35
	35 × 30	2330	1.40	LGG2P102MELC30
1200	30 × 40	2500	1.54	LGG2P122MELB40
	35 × 30	2350	1.54	LGG2P122MELC30
1500	30 × 45	2550	1.72	LGG2P152MELB45
	35 × 35	2500	1.72	LGG2P152MELC35
1800	35 × 40	2700	1.88	LGG2P182MELC40
2200	35 × 50	2950	2.08	LGG2P222MELC50

定格リップル電流 (mA_{RMS}) at 105°C 120Hz

アルミニウム電解コンデンサ ALUMINUM ELECTROLYTIC CAPACITORS



■寸法表

250V (2E)				
定格静電容量 (μF)	サイズ φDXL (mm)	リップル (mA)	漏れ電流 (mA)	品番
390	22×30	1200	0.93	LGG2E391MELZ30
	25×25	1200	0.93	LGG2E391MELA25
470	22×35	1300	1.02	LGG2E471MELZ35
	25×30	1300	1.02	LGG2E471MELA30
560	22×40	1400	1.12	LGG2E561MELZ40
	25×35	1500	1.12	LGG2E561MELA35
	30×25	1400	1.12	LGG2E561MELB25
680	22×45	1500	1.23	LGG2E681MELZ45
	25×40	1700	1.23	LGG2E681MELA40
	30×30	1700	1.23	LGG2E681MELB30
820	25×45	2000	1.35	LGG2E821MELA45
	30×35	2000	1.35	LGG2E821MELB35
	35×30	2000	1.35	LGG2E821MELC30
	25×50	2200	1.50	LGG2E102MELA50
1000	30×40	2200	1.50	LGG2E102MELB40
	35×30	2000	1.50	LGG2E102MELC30
	30×45	2300	1.64	LGG2E122MELB45
1200	35×35	2200	1.64	LGG2E122MELC35
	30×50	2300	1.83	LGG2E152MELB50
1500	35×40	2300	1.83	LGG2E152MELC40
	35×45	2500	2.01	LGG2E182MELC45

400V (2G)				
定格静電容量 (μF)	サイズ φDXL (mm)	リップル (mA)	漏れ電流 (mA)	品番
120	22×25	680	0.65	LGG2G121MELZ25
180	22×30	730	0.80	LGG2G181MELZ30
	25×25	730	0.80	LGG2G181MELA25
220	22×35	850	0.88	LGG2G221MELZ35
	25×30	850	0.88	LGG2G221MELA30
270	22×40	1000	0.98	LGG2G271MELZ40
	25×35	1000	0.98	LGG2G271MELA35
	30×25	1000	0.98	LGG2G271MELB25
330	22×50	1150	1.08	LGG2G331MELZ50
	25×40	1150	1.08	LGG2G331MELA40
	30×30	1150	1.08	LGG2G331MELB30
	35×25	1150	1.08	LGG2G331MELC25
390	25×45	1400	1.18	LGG2G391MELA45
	30×35	1400	1.18	LGG2G391MELB35
	35×30	1550	1.18	LGG2G391MELC30
470	25×50	1550	1.30	LGG2G471MELA50
	30×40	1550	1.30	LGG2G471MELB40
	35×30	1550	1.30	LGG2G471MELC30
560	30×45	1630	1.41	LGG2G561MELB45
	35×35	1630	1.41	LGG2G561MELC35
680	30×50	1800	1.56	LGG2G681MELB50
	35×40	1800	1.56	LGG2G681MELC40
820	35×45	2000	1.71	LGG2G821MELC45
1000	35×50	2140	1.89	LGG2G102MELC50

420V (W6)				
定格静電容量 (μF)	サイズ φDXL (mm)	リップル (mA)	漏れ電流 (mA)	品番
120	22 × 30	810	0.67	LGGW6121MELZ30
150	22 × 35	840	0.75	LGGW6151MELZ35
	25 × 25	820	0.75	LGGW6151MELA25
180	22 × 35	850	0.82	LGGW6181MELZ35
	25 × 30	910	0.82	LGGW6181MELA30
220	22 × 40	950	0.91	LGGW6221MELZ40
	25 × 35	1050	0.91	LGGW6221MELA35
	30 × 25	950	0.91	LGGW6221MELB25
270	22 × 50	1150	1.01	LGGW6271MELZ50
	25 × 40	1250	1.01	LGGW6271MELA40
	30 × 30	1250	1.01	LGGW6271MELB30
330	25 × 45	1350	1.11	LGGW6331MELA45
	30 × 35	1420	1.11	LGGW6331MELB35
	35 × 30	1420	1.11	LGGW6331MELC30
390	25 × 50	1450	1.21	LGGW6391MELA50
	30 × 40	1610	1.21	LGGW6391MELB40
	35 × 30	1450	1.21	LGGW6391MELC30
470	30 × 45	1860	1.33	LGGW6471MELB45
	35 × 35	1700	1.33	LGGW6471MELC35
560	35 × 40	1900	1.45	LGGW6561MELC40
680	35 × 45	2050	1.60	LGGW6681MELC45

450V (2W)				
定格静電容量 (μF)	サイズ φDXL (mm)	リップル (mA)	漏れ電流 (mA)	品番
100	22×25	640	0.63	LGG2W101MELZ25
120	22×30	690	0.69	LGG2W121MELZ30
	25×25	690	0.69	LGG2W121MELA25
150	22×35	720	0.77	LGG2W151MELZ35
	25×30	790	0.77	LGG2W151MELA30
180	22×40	790	0.85	LGG2W181MELZ40
	25×30	790	0.85	LGG2W181MELA30
220	22×45	870	0.94	LGG2W221MELZ45
	25×35	870	0.94	LGG2W221MELA35
	30×30	790	0.94	LGG2W221MELB30
270	22×50	1050	1.04	LGG2W271MELZ50
	25×40	1050	1.04	LGG2W271MELA40
	30×30	1050	1.04	LGG2W271MELB30
	35×25	1050	1.04	LGG2W271MELC25
330	25×50	1200	1.15	LGG2W331MELA50
	30×35	1200	1.15	LGG2W331MELB35
	35×30	1200	1.15	LGG2W331MELC30
390	30×40	1380	1.25	LGG2W391MELB40
	35×35	1380	1.25	LGG2W391MELC35
470	30×45	1550	1.37	LGG2W471MELB45
	35×40	1550	1.37	LGG2W471MELC40
560	35×45	1700	1.50	LGG2W561MELC45
680	35×50	1910	1.65	LGG2W681MELC50

定格リップル電流 (mArms) at 105°C 120Hz

●定格リップル電流の周波数補正係数

周波数 (Hz)	50	60	120	300	1k	10k	50k~	
係数	160~250V	0.81	0.85	1.00	1.17	1.32	1.45	1.50
	400~450V	0.77	0.82	1.00	1.16	1.30	1.41	1.43