

Analog Two Way Radio IC for Toy Walkie-Talkie and Remote Controller

Feature

- Operating Frequency
24MHz~32MHz 128MHz~170MHz
35MHz~57MHz 384MHz~512MHz
- 12.5/25 kHz Channel Spacing
- On-chip FM Mod/De-mod
- On-chip ASK Mod/De-mod
- On-chip 10dBm RF Power Amplifier
- On-chip RF T/R Switch
- On-chip Microphone Amplifier
- On-chip 250mW Audio Amplifier
- On-chip ROM Support 16 Channels
- 2.5V~3.3V Supply Voltage
- Minimum RX Waiting Current 2.3mA
- Power-down Current Less than 100nA
- Auto Squelch
- Auto Power Saving
- I2C Interface
- Can Work without MCU
- Can Work with External EEPROM
- QFN 4x4 32PIN Package

Applications

- Toy Walkie-Talkie Radios
- Remote Controller
- Personal Radio Service

General Description

BK4802N is a half duplex TDD FM/ASK transceiver IC designed for worldwide toy walkie-talkie and remote controller. It utilizes advanced CMOS technology, integrates a RF transceiver, FM/ASK Demodulation, FM/ASK Modulation, a Microphone Amplifier, an Audio Power Amplifier and a XTAL Oscillator.

A high performance and low cost RF module can be realized by incorporating BK4802N with a 21.25MHz XTAL and several SMD capacitors.

BK4802 can work independently without MCU for voice communication. 16 built-in channels can be chosen by PIN B0/C0. Other channels can be configured by using an external EEPROM.

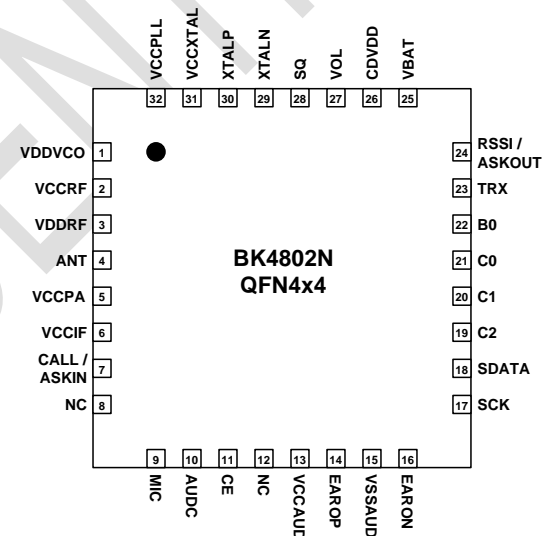

QFN 32PIN Assignment (TOP View)

Function Block Diagram

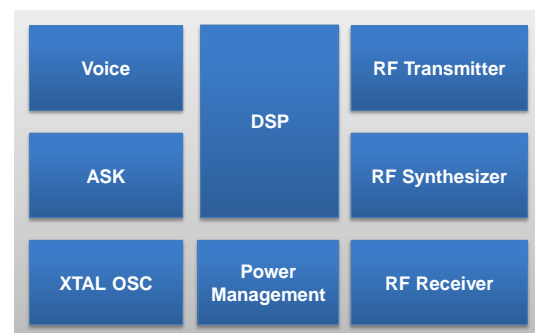

1 Function Description

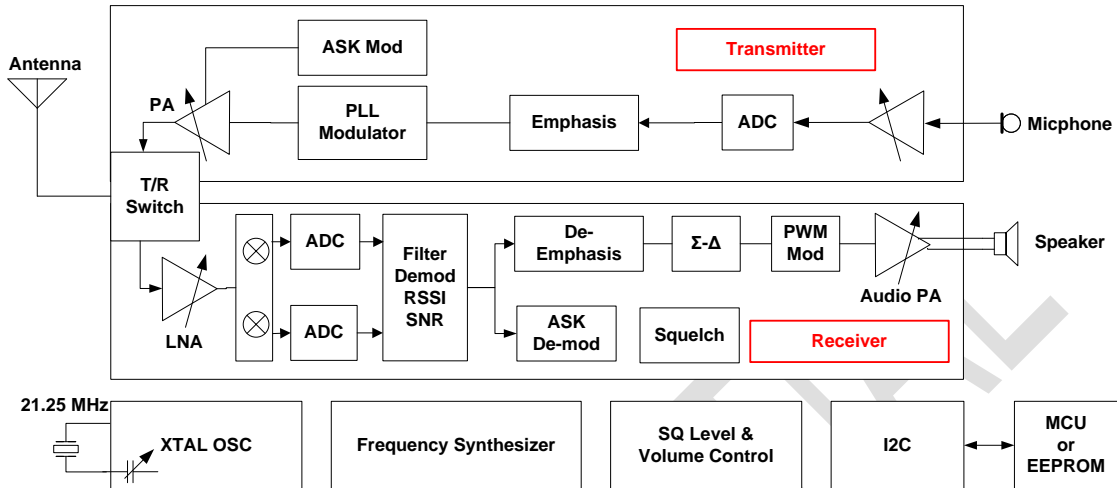

Figure 1 Block Diagram

BK4802N integrates a high performance RF PLL, several ADC, a DAC, a RF receiver and a RF transmitter, a T/R switch, a microphone amplifier and a 250mW audio power amplifier, and has powerful digital signal processing capability. Digital low-IF architecture leads to high integration, requires only a 21.25MHz XTAL, a microphone, a speaker, an antenna and several SMD resistors/capacitors to form a two way radio module. On-chip ROM stores the information of 16 built-in channels. BK4802N can work independently without MCU for voice communication. 3 applications using BK4802N are shown in the figure below.

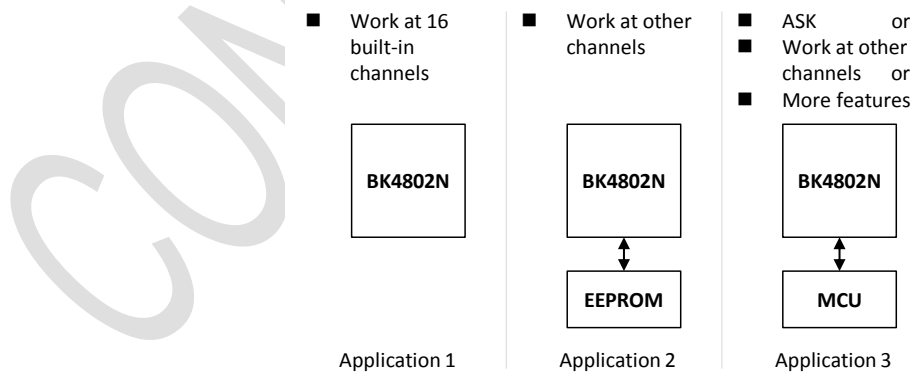

Figure 2 Several Applications using BK4802N

As illustrated in the figure above, EEPROM can be introduced if the wanted channel is not included in these 16 built-in channels. BK4802N access EEPROM through 2 wires I2C interface. Also, BK4802N can work with MCU for data communication in ASK mode. MCU can read or write registers in BK4802N through I2C interface, too.

2 Electrical Specification

1.1 Absolute Maximum Ratings

Maximum ratings are the extreme limits to which BK4802N can be exposed without permanently damaging it. Exposure to absolute maximum ratings for prolonged periods of time may affect BK4802N's reliability. Table 1 specifies the absolute maximum ratings for BK4802N.

Table 1 Absolute Maximum Ratings

Parameter	Symbol	Min	Typ	Max	Unit
Supply Voltage	V_{DD}	-0.3	—	+3.6	V
I/O Pin Voltage	V_{IO}	-0.3	—	$V_{DD}+0.3$	V
Storage Temperature	T_S	-20	25	85	°C

1.2 Recommended Operating Conditions

The operating conditions are the physical parameters that BK4802N can operate within. The operating conditions for BK4802N are defined in Table 2.

Table 2 Recommended Operating Conditions

Parameter	Symbol	Min	Typ	Max	Unit
Supply Voltage	V_{DD}	2.5	—	3.3	V
Operating Temperature	T_O	-10	25	60	°C

Notes:

All minimum and maximum specifications are guaranteed and apply across the recommended operating conditions. Typical values apply at $V_{DD}=3.3$ V and 25 °C unless otherwise stated. Parameters are tested in production unless otherwise stated.

For QFN4x4 32pin package, V_{DD} range is 2.5-3.3V.

The range of operating temperature mainly depends on the specification of the crystal. The frequency tolerance of the crystal should be within +/-2.5ppm during all operating conditions

1.3 Power Consumption Specification

Table 3 Power Consumption

Parameter	Symbol	Min	Typ	Max	Unit	Parameter
RX Current	I_{RX}	$V_{DD}=3.3V, CE = H$ TRX = L Audio PA OFF	—	21	—	mA
RX Waiting Current	I_{RX_Wait}	$V_{DD}=3.3V, CE = H$ TRX = L Audio PA OFF Power Saving	—	2.3	—	mA
TX Current	I_{TX}	$V_{DD}=3.3V, CE = H$ TRX = H	—	20	—	mA
Power-down Current	I_{PD}	$V_{DD}=3.3V, CE = L$	—	50	—	nA

1.4 Receiver Characteristics

Table 4 Receiver Characteristics

Parameter	Symbol	Test Condition	Min	Typ	Max	Unit
Operating Frequency	F _{OP}	1	384	—	512	MHz
		2	128	—	170	
		3	35	—	57	
		4	24	—	32	
FM Sensitivity	RXSENS	5, 9		-114		dBm
Adjacent Channel Selectivity	ACS	6		44	45	dB
Blocking	BLK	7		62	65	dB
Inter-modulation	IMD	8		36	44	dB
Audio						
Audio Output Power	PAUD	9			300	mW
RX SINAD	RSINAD	9, 10		42	44	dB
Audio Output Noise Floor	ANF	11	1	7		uW
ASK						
ASK Sensitivity (1E-3 BER)	ASKSEN	12		-100		dBm
Baud Rate	BAUD				2000	bps
Test Condition: 1. Band 1 2. Band 2 3. Band 3, Band 4 4. Band 5 5. 12 dB SINAD, typical value acquired at 27.125MHz 6. 1 st adjacent channel (± 25 kHz), typical value measured at 462.5625MHz, maximum value measured at 27.125MHz 7. Frequency offset = 1MHz, typical value measured at 462.5625MHz, maximum value measured at 27.125MHz 8. According to TIA-603-C, typical values measured at 462.5625MHz, maximum value measured at 27.125MHz 9. AF FREQ 300Hz, AF Deviation 3kHz. Measured on 8Ohm speaker 10. -50dBm RF input power 11. -50dBm RF input power, single tone. Measured on 8 Ohm speaker. Typical valued measured at 462.5625MHz, minimum value measured at 27.25MHz 12. Baud rate 1kbps						

1.5 Transmitter Characteristics

Table 5 Transmitter Characteristics

Parameter	Symbol	Test Condition	Min	Typ	Max	Unit
Operating Frequency	F _{OP}	1	384	—	512	MHz
		2	128	—	170	
		3	35	—	57	
		4	24	—	32	
Output Power	POUT	5	-40	—	12	dBm
Adjacent Channel Power Rejection	ACPR	6		61	73	dB
Microphone Sensitivity	MICSENS	7		0.5		mV
TX SINAD	TSINAD	7		33		dB
Test Condition: 1. Band 1 2. Band 2 3. Band 3, Band 4, Band 5 4. Band 6, Band 7, Band 8 5. Depend on register settings, off-chip matching and channels 6. 1 st adjacent channel(±25kHz) according to TIA-603-C. Typical value measured at 462.5625MHz, maximum value measured at 27.125MHz 7. AF FREQ = 1kHz, AF Deviation = 3kHz						

1.6 Built-in Channels

BK4802N has 16 built-in channels, and the frequency information of these 16 channels is stored in on-chip 4kbits ROM. After power-up, state machine in BK4802N will choose corresponding channels according to the voltage level of B0/C2/C1/C0 in 50ms. Then write channel information into registers. The relationship of channel No., PIN voltage and frequency is given in the table below.

Table 6 The relationship among channel No., PIN voltage and frequency

Channel No.	PIN Voltage B0/C2/C1/C0	Frequency (MHz)	Channel No.	PIN Voltage B0/C2/C1/C0	Frequency (MHz)
1	L / L / L / L	27.125	9	H / L / L / L	422.05
2	L / L / L / H	27.145	10	H / L / L / H	434.125
3	L / L / H / L	40.665	11	H / L / H / L	433.075
4	L / L / H / H	40.685	12	H / L / H / H	446.00625
5	L / H / L / L	49.86	13	H / H / L / L	448.7625
6	L / H / L / H	49.89	14	H / H / L / H	462.5625
7	L / H / H / L	409.75	15	H / H / H / L	462.6625
8	L / H / H / H	433.92	16	H / H / H / H	477.325

1.7 I2C Interface Characteristics

The I2C interface in BK4802N accords with the timing requirement of standard I2C. It can work both at master mode and slave mode. When using with an external EEPROM, I2C interface work at master mode. When using with an external MCU, I2C interface work at slave mode.

Timing requirements of I2C interface are listed in the table below.

Table 7 I2C Interface Characteristics

Parameter	Symbol	Min	Typ	Max	Unit
SCLK Frequency	f_{SCL}	—	—	400	kHz
SCLK Low Time	t_{LOW}	1.3	—	—	μs
SCLK High Time	t_{HIGH}	0.6	—	—	μs
SCLK Input to SDIO \downarrow Setup (START)	$t_{SU:STA}$	0.6	—	—	μs
SCLK Input to SDIO \downarrow Hold (START)	$t_{HD:STA}$	0.6	—	—	μs
SDIO Input to SCLK \uparrow Setup	$t_{SU:DAT}$	100	—	—	ns
SDIO Input to SCLK \downarrow Hold	$t_{HD:DAT}$	—	—	900	ns
SCLK Input to SDIO \uparrow Setup (STOP)	$t_{SU:STO}$	0.6	—	—	μs
STOP to START Time	t_{BUF}	1.3	—	—	μs
SDIO Output Fall Time	$t_{f:OUT}$	—	—	250	ns
SDIO Input, SCLK Rise/Fall Time	$t_{r:IN}$	—	—	200	ns
	$t_{f:IN}$	—	—	200	ns
SCLK, SDIO Capacitive Loading	C_b	—	—	60	pF
Input Filter Pulse Suppression	t_{SP}	—	—	40	ns

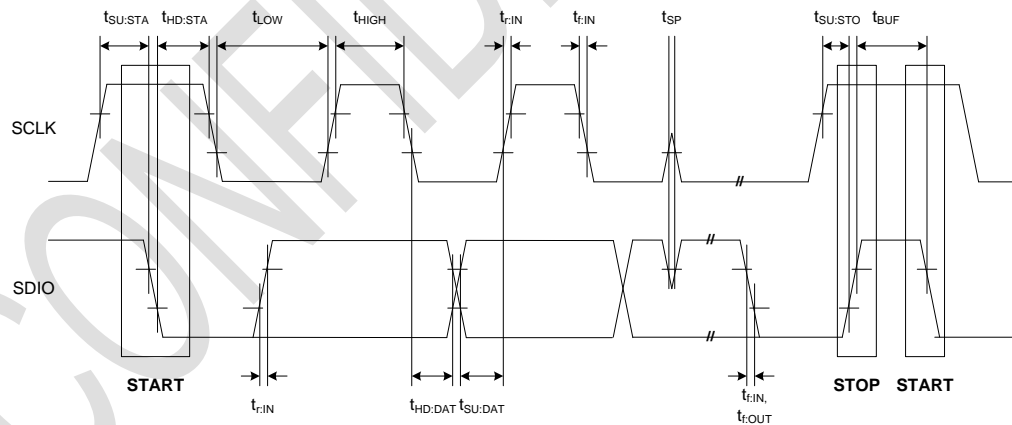

Figure 3 Read/Write Timing of I2C Interface

3 Register Definition

Table 8 Register Definition

Address (DEC)	Function	Default Value	Description
0	W/R		High 16 bits of Frac-N
1	W/R		Low 16 bits of Frac-N
2	W/R		B15~B13: Divider Ratio(Ndiv) from VCO to LO B04~B00: TX Audio Deviation Expander, inversely proportional to Ndiv
3	W/R		Reserved
4	Write Only	0x0300 (RX) 0x7C00 (TX) 0xFFBF (IDLE)	B15: 1-Disable Synthesizer; 0-Enable Synthesizer B14: 1-Disable RX Front-end; 0-Enable RX Front-end B13: 1-Disable RX IF; 0-Enable RX IF B12: 1-Disable RX ADC; 0-Enable RX ADC B11: 1-Disable RX Audio; 0-Enable RX Audio B10: 1-Disable SAR ADC; 0-Enable SAR ADC B09: 1-Disable TX PA; 0-Enable TX PA B08: 1-Disable TX Audio; 0-Enable TX Audio B07: 1-Disable Bias; 0-Enable Bias B06: 1-Disable XTAL Buffer; 0-Enable XTAL Buffer
5	Write Only	0x0C04 (RX) 0x0004 (TX)	Settings for TXAL Oscillator and SAR ADC. Please use default value
6	Write Only	0xF140	Settings for TX Audio and RX Audio. Please use default value
7	Write Only	0xED00	B15~B13: RX IF Gain, 3dB/step. 0-0dB;...7-21dB
8	Write Only	0x17E0	B07~B05: Power level of TX PA B04: 1-Enable ASK TX; 0-Disable ASK TX B03: 1-Low Current Mode(16mA); 0-Normal Mode(21mA)
9	Write Only	0xE0E0	B13: 1-T/R Control by DSP; 0-T/R Control by Register B12: 1-PLL in TX Mode; 0-PLL in RX Mode B11: 1-RF Switch in TX Mode; 0-RF Switch in RX Mode
10	Write Only	0x8543	Settings for PLL. Please use default value
11	Write Only	0x0700	Settings for PLL. Please use default value
12	Write Only	0xA066	B00: VCO Calibration 0 -> 1 -> 0
13	Write Only	0xFFFF	Settings for PLL. Please use default value
14	W/R	0xFFE0	B15~B14: Gain of Digital Filters in TX Audio Path 0-0dB; 1-1dB; 2-3.5dB; 3-6dB B13~B09: Volume of TX Audio B08~B05: In-band Signal Deviation
15	W/R	0x061F	B12~B00: Limiter for TX Audio
16	W/R	0x9E3C	B15: Enable AGC for TX Audio. 0-Disable; 1-Enable
17	W/R	0x1F00	Settings for TX Audio AGC. Please use default value
18	W/R	0xD1D1	B05~B03: Speaker on if ON conditions last for T seconds 0-100ms 1-200ms 2-300ms 3-400ms 4-500ms 5-600ms 6-700ms 7-800ms B02~B00: Speaker off if OFF conditions last for T seconds 0-100ms 1-200ms 2-300ms 3-400ms 4-500ms 5-600ms 6-700ms 7-800ms

19	W/R	0x200F	B15~B14: CIC Filter Gain. 0-0dB; 1-1dB; 2-3.5dB; 3-6dB B13~B12: Output Amplitude of FM Demodulator B03~B00: RX Audio Volume
20	W/R	0x01FF	B15: Disable AFC. 0-Enable; 1-Disable
21	W/R	0xE000	Settings for AFC. Please use default value
22	W/R	0x0340	B11~B10: Ex-noise Coefficient for Speaker OFF Condition B07~B00: RSSI Threshold for Speaker ON Condition
23	W/R	0x98E0	B15: 1-Enable Power Saving; 0-Disable Power Saving B14~B13: RX Active Period in Power Saving Mode 0-60ms 1-108ms 2-144ms 3-192ms B12~B11: Sleep Period in Power Saving Mode 0-384ms 1-576ms 2-768ms 3-960ms B08: 1-PIN7 is ASKIN, PIN24 is ASKOUT 0-PIN7 is CALL, PIN24 is RSSI B07~B00: Ex-noise Threshold for Speaker ON Condition
24	Read Only		B13~B08: SNR Indicator B06~B00: RSSI Indicator
25	Read Only		B07~B00: AFC Residual Frequency
26	Read Only		B12~B00: Ex-noise Indicator
27	Read Only	0x4802	Chip ID
28	Read Only		High 16 bits of Device ID
29	Read Only		Low 16 bits of Device ID
30	Read Only		B15~B08: RX Volume Indicator from SAR ADC B07~B00: Ex-noise Threshold for Speaker OFF Condition Acquired from SAR ADC
31	Read Only		B07~B00: RSSI Threshold for Speaker OFF Condition Acquired from SAR ADC
32	W/R		B14: ASK Data Decision by. 0-Averaged Value; 1-REG33 B13: Average Speed. 0-256 samples; 1-1024 samples B12: Bypass Low Pass Filter. 0-Valid; 1-Bypass B08: RX Volume set by. 0-PIN VOL; 1-REG32<07:00> B07~B00: Set the Volume of RX Audio
33	W/R		B15~B00: Threshold for "0"/"1" ASK Data Decision

4 Pin Assignment

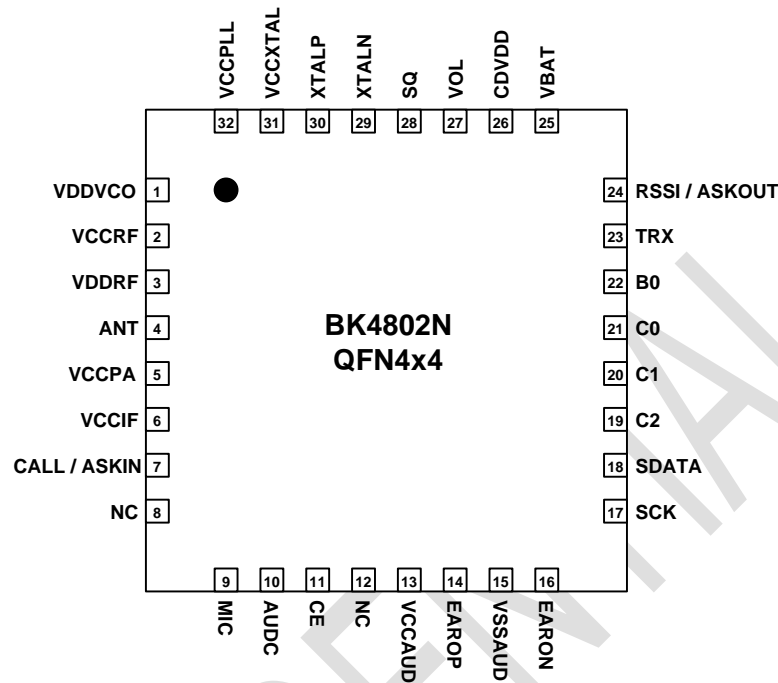

Figure4BK4802N QFN4x4 32PIN Assignment(TOP View)

Table 9BK4802N QFN4x4 32PIN Definition

PIN No.	PIN Name	Description
1	VDDVCO	VCO LDO output, need external decoupling capacitor
2	VCCRF	Power Supply, 2.5 V~ 3.3 V
3	VDDRF	RX FE LDO output, need external decoupling capacitor
4	ANT	RF Port
5	VCCPA	Power Supply, 2.5 V~ 3.3 V
6	VCCIF	Power Supply, 2.5 V~ 3.3 V
7	CALL / ASKIN	PIN Re-use. Default as CALL, can be configured as ASKIN by register
8	NC	No Connection. Please keep floating
9	MIC	Microphone Signal input
10	AUDC	Common mode node of Microphone Amplifier, need external 1uF capacitor to ground
11	CE	Chip Enable. H – Enable, L – Disable
12	NC	No Connection. Please keep floating

13	VCCAUD	Power Supply, 2.5 V~ 3.3 V
14	EAROP	Positive output of Audio Power Amplifier
15	VSSAUD	Ground
16	EARON	Negative output of Audio Power Amplifier
17	SCK	I2C CLK
18	SDATA	I2C Data Input/Output
19	C2	Channel Selection
20	C1	Channel Selection
21	C0	Channel Selection
22	B0	Channel Selection
23	TRX	TX/RX Mode Selection. H – TX Mode, L – RX Mode
24	ASKOUT	PIN Re-use. Default as RSSI, can be configured as ASKOUT by register
25	VBAT	Power Supply, 2.5 V~ 3.3 V
26	CDVDD	Digital LDO output, need external decoupling capacitor
27	VOL	Volume Adjustment, 0~1.2V
28	SQ	Squelch Level Adjustment, 0~1.2V
29	XTALN	Negative output of XTAL Oscillator
30	XTALP	Positive output of XTAL Oscillator
31	VCCXTAL	Power Supply, 2.5 V~ 3.3 V
32	VCCPLL	Power Supply, 2.5 V~ 3.3 V

5 Typical Application Schematic

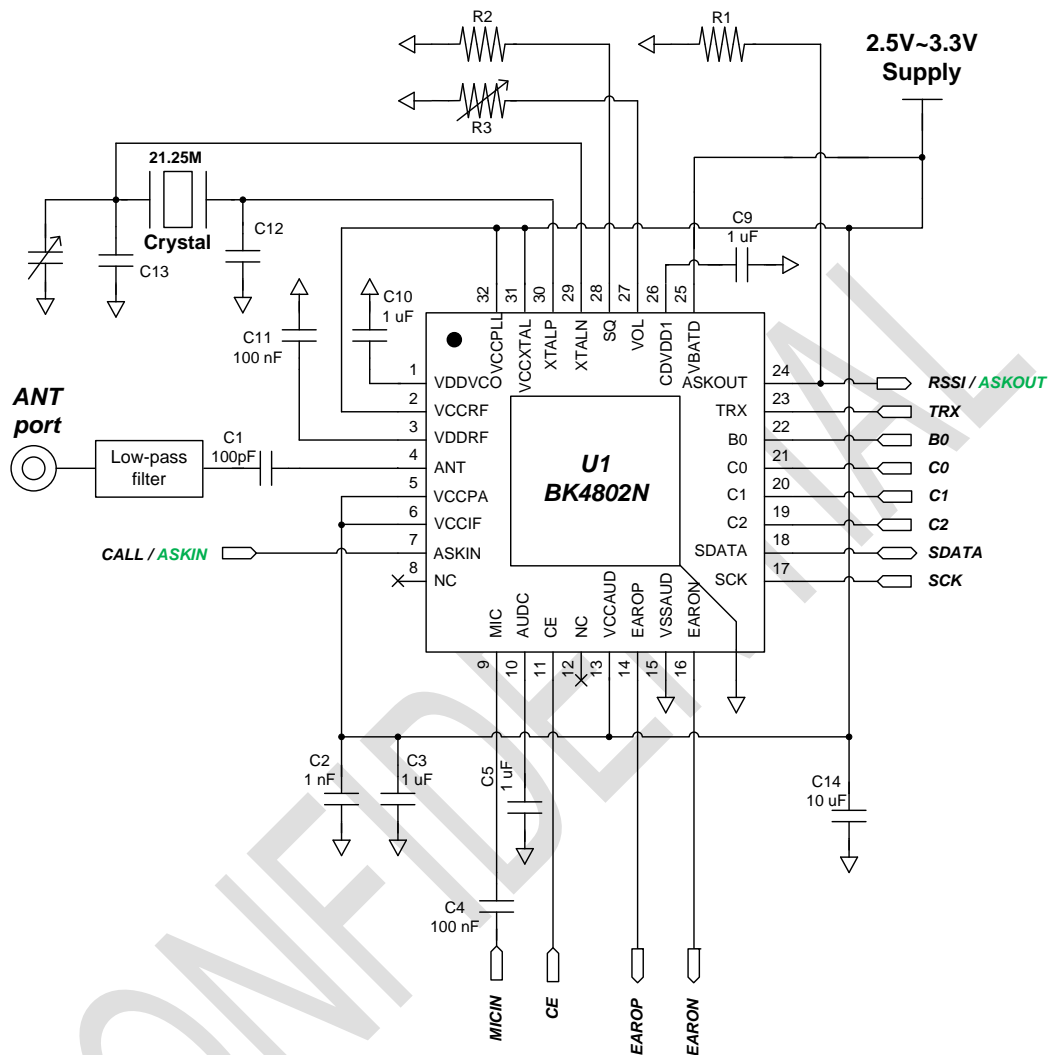

Figure 5BK4802N Typical Application Schematic

6 Package Information

QFN 4mmx4mm 32pin package is available for BK4802N. Detail information of the package is shown below:

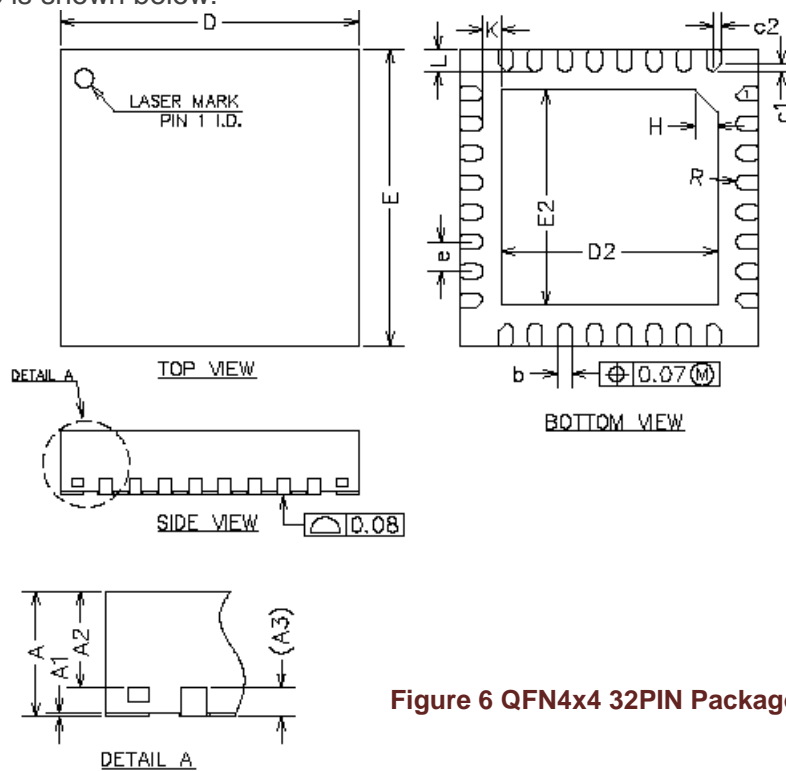

Figure 6 QFN4x4 32PIN Package Diagram

Table 10 QFN4x4 32PIN Package Dimensions

Parameter	Min	Typ	Max	Unit
A	0.80	0.85	0.90	mm
A1	0.00	0.02	0.05	mm
A2	0.60	0.65	0.70	mm
A3	0.20 REF			mm
b	0.15	0.20	0.25	mm
D	3.90	4.00	4.10	mm
E	3.90	4.00	4.10	mm
D2	2.80	2.90	3.00	mm
E2	2.80	2.90	3.00	mm
e	0.30	0.40	0.50	mm
H	0.30 REF			mm
K	0.25 REF			mm
L	0.25	0.30	0.35	mm
R	0.09	–	–	mm
c1	–	0.10	–	mm
c2	–	0.10	–	mm

Table 11 Soldering Layer Content

Content	Width	Unit
Ni	0.5-2.0	um
Pd	0.02-0.15	um
Au	0.003-0.015	um

Storage Caution

1. Calculated shelf life in vacuum sealed bag 12 months at 40°C and 90% relative humidity (RH).
2. Peak package body temperature 260°C .
3. After vacuum sealed bag is opened, devices that will be subjected to reflow solder or other high temperature process must
 - 1) Mounted within 168 hours of factory conditions $40^{\circ}\text{C}/60\%$;
 - 2) Stored at 10% RH.

7 Tape and Reel Information

All dimensions are in millimeters by default.

6.1 Tape Information

The figure below shows the dimensions of the tape for the BK4802N QFN.

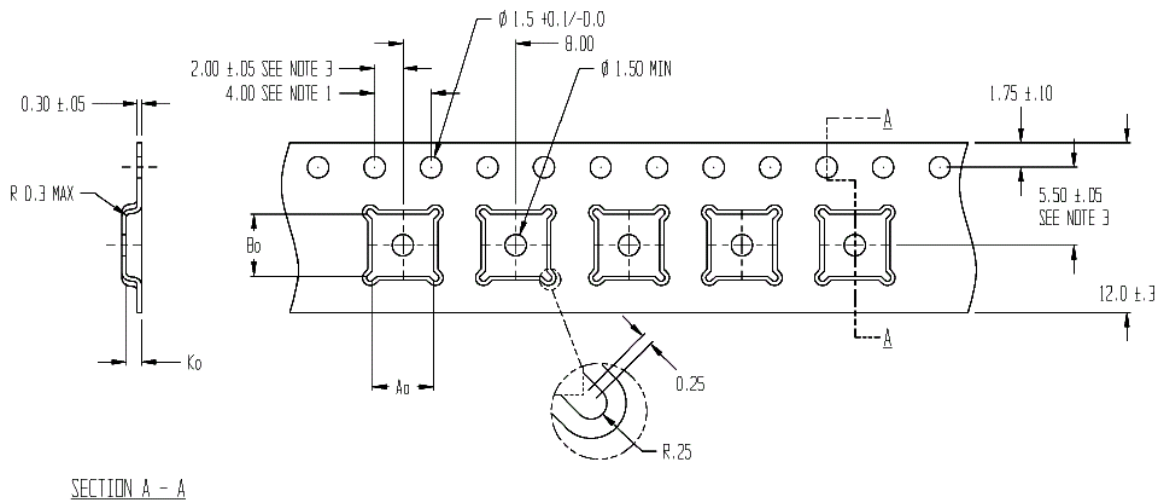

Figure 7 Tape Dimensions

A_0	B_0	K_0	Unit	Notes
4.35	4.35	1.1	mm	<ol style="list-style-type: none"> 10 sprocket hole pitch cumulative tolerance ± 0.2. Camber in compliance with EIA 481. Pocket position relative to sprocket hole measured as true position of pocket, not pocket hole.

6.2 Cover Information

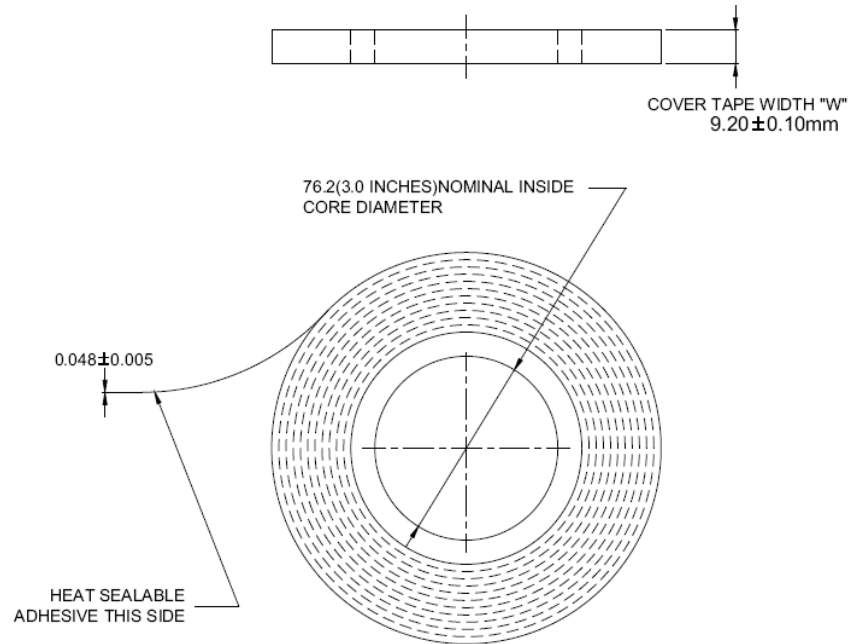

Figure 8 Cover Dimensions

Notes:

1. Reel to contain 300 meters of splice free material
2. Material: Polyester film with antistatic coating and adhesive coating
3. Color: Transparent, natural

6.3 Reel Information

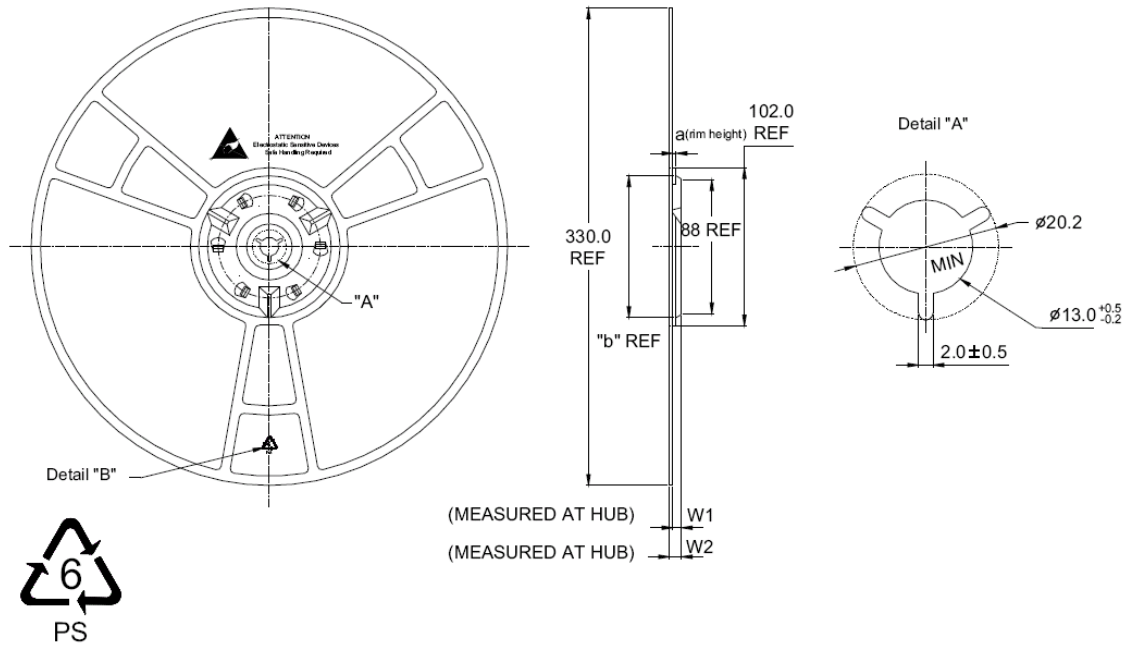

Figure 9 Reel Dimensions

Nominal Hub Width	W1	+0.6mm -0.4mm	W2 MAX	a	b	Unit
12	12.8		18.2	1.5	96.5	mm

8 Order Information

Part Number	Package	Packing	MOQ (ea)
BK4802NQB	QFN4x4 32PIN	Tape Reel	3K

MOQ: Minimum Order Quantity

CONFIDENTIAL

9 Revision History

Version	Change Summary	Date	Author
Rev.1.0	Initial Draft	2016/06/17	PH
Rev.1.1	Based on F version, H version update the ROM value to change 4 built-in channels. And, the description about these 16 built-in channels in section 1.6 is updated correspondingly.	2017/09/05	PH

CONFIDENTIAL

10 Contact Information

Beken Corporation Technical Support Center

Website: www.bekencorp.com
Email: info@bekencorp.com

Shanghai Headquarters

Building 41, Capital of Tech Leaders, 1387 Zhangdong Road, Zhangjiang High-Tech Park,
Pudong New District, Shanghai, China
Phone: 86-21-51086811, 60871276
Fax: 86-21-60871277
Postcode: 201203

Shenzhen Branch

Room 310, HKUST SZ IER Building, No. 9 Yuexing 1st Rd., Nanshan Hi-Tech Park,
Shenzhen, China
Phone: 86-755-2655 1063
Postcode: 518057

Taipei Branch

2F-1, No. 49, Ln. 35, Jihu Rd., Neihu,
Taipei 114, Taiwan
Phone: 886-2-26275780