1. FUNCTIONS & FEATURES

Features

- Characters: 16×2 Lines
- LCD Mode: STN Gray/Transflective,Positive
- Controller IC: AIP31066 or Equivalent
- Driving Method: 1/16 Duty; 1/5Bias
- Viewing Angie: 6 O'clock direction
- 6800 serial 8-Bit/4-Bit MPU Interface
- Backlight: LED Yellow –Green
- Operating Temperature Range: -20 to 70°C;
- Storage Temperature Range : -30 to 80°C;

2. MECHANICAL SPECIFICATIONS

ITEM	SPECIFICATIONS	UNIT
Module Size	53.0L×20.0W×8.4 (max) H	mm
View Area	36.0×10.0	mm
Number of Character	16×2 Lines	—
Character Size	1.85×3.15	mm
Character Pitch	2.15×4.25	mm

3. EXTERNAL DIMENSIONS

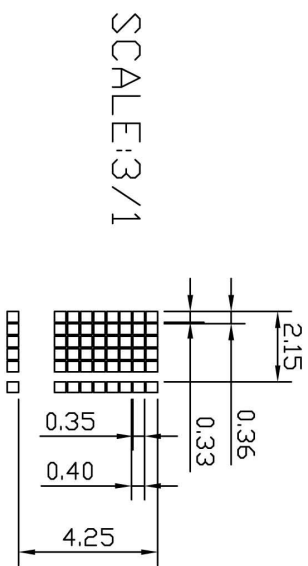
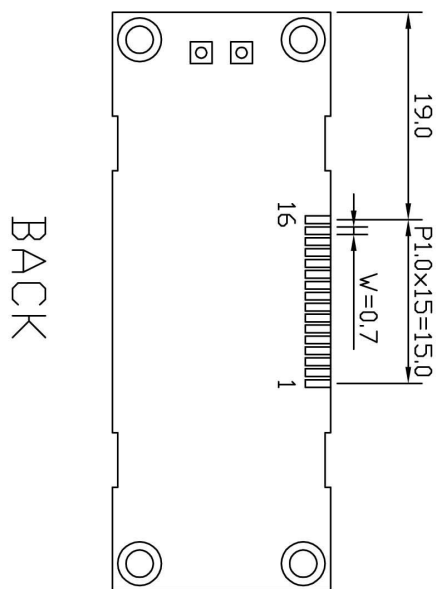
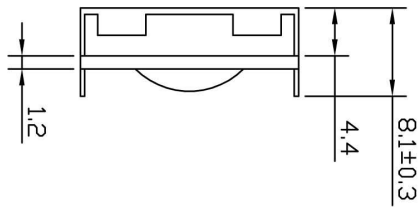
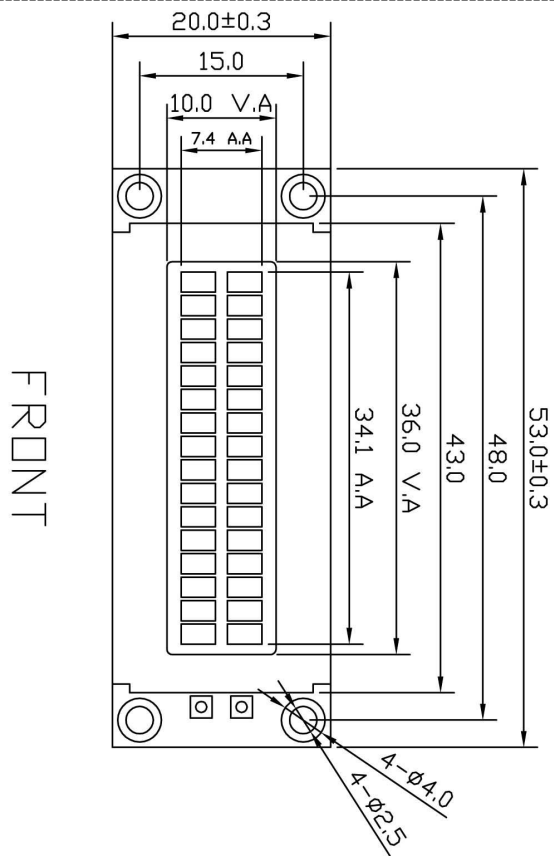

4. BLOCK DIAGRAM

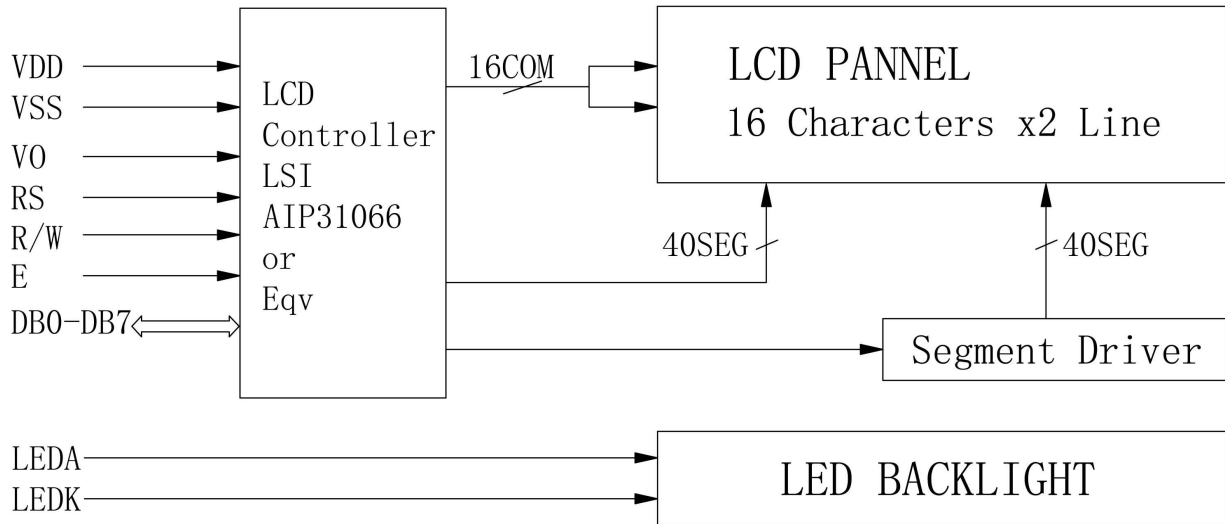

5. POWER SUPPLY

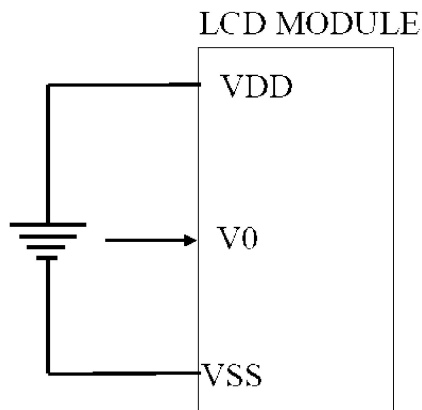

VDD-V0=Operating voltage for LCD

6. PIN DESCRIPTION

ITEM	SYMBOL	LEVEL	FUNCTION
1	VSS	0V	Power Ground
2	VDD	5.0V	Power Supply For Logic
3	V0	-	Operating Voltage for LCD
4	RS	H/L	H: Data L: Command
5	R/W	H/L	H: Read L: Write
6	E	H, H->L	Enable Signal
7-10	DB0-DB3	H/L	Data Bus Line 4-bit Low
11-14	DB4-DB7	H/L	Data Bus Line 4-bit High
15	LEDA	5.0V	LED Backlight Anode
16	LEDK	0V	LED Backlight Cathode

6.1. Adjusting The LCD Display Contrast

A Variable-Resistor must be connected to the LCD module for providing a reference to V0. The recommended value of the Variable-Resistor is 10K to 20K.

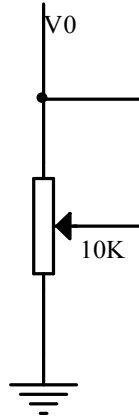

7. MAXIMUM ABSOLUTE LIMIT (Ta=25°C)

Items	Symbol	Min	Max	Unit	Condition
Supply Voltage	Vdd	-0.3	7.0	V	Vss=0V
Input Voltage	Vin	VDD-10.0V	VDD+0.3V	V	Vss=0V
Operating Temperature	Top	-20	70	°C	No Condensation
Storage Temperature	Tst	-30	80	°C	No Condensation

Note: Voltage greater than above may damage the module

All voltages are specified relative to Vss=0V

8. ELECTRICAL CHARACTERISTICS

8.1 DC Characteristics (VDD=+5.0V, VSS=0V, Ta=-0~+50°C)

Items	Symbol	Min	Type	Max	Unit	Condition
Operating Voltage	VDD	4.5V	5.0	5.5	V	VDD
Supply Current	IDD	—	1.5	3.0	mA	except LED backlight
Input High Voltage	Vin	0.7VDD	—	VDD	V	RS,RW,E,DB0-DB7
Input Low Voltage	Vil	-0.3	—	0.6	V	
Output High Voltage	Voh	3.9	—	VDD	V	Ioh=-0.1mA,DB0-DB7
Output Low Voltage	Vol	—	—	0.4	V	Iol=0.1mA,DB0-DB7
LCM Driving Voltage	Vop	4.2	4.4	4.6	V	

8.2 AC Characteristics (VDD=+5.0V, VSS=0V, Ta=-20~75°C)

Items	Symbol	Min	TYP	Max	Unit
E cycle time	tc	1500	—	—	nS
E high level width	tpw	175	—	—	nS
E rise time	tr	—	—	20	nS
E fall time	tf	—	—	20	nS
Address set-up time	tas	5	—	—	nS
Address hold time	tah	13	—	—	nS
Data set-up time	tdsw	50	—	—	nS

Data delay time	t _{DDR}	—	—	125	nS
Data hold time	t _H	13	—	—	nS

MPU write timing

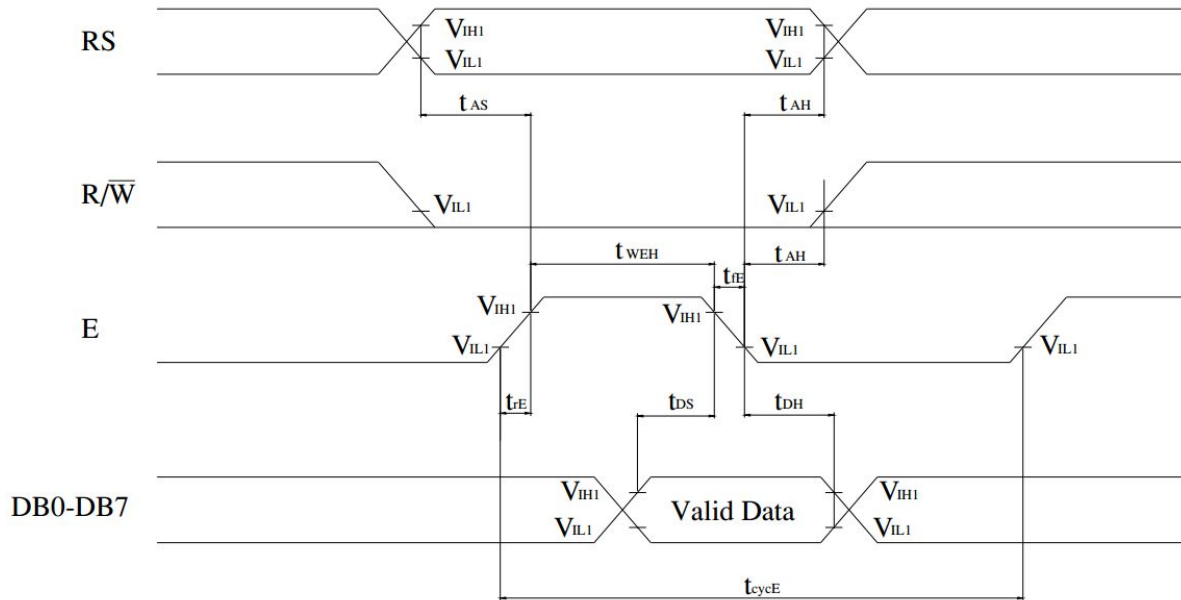

MPU read timing

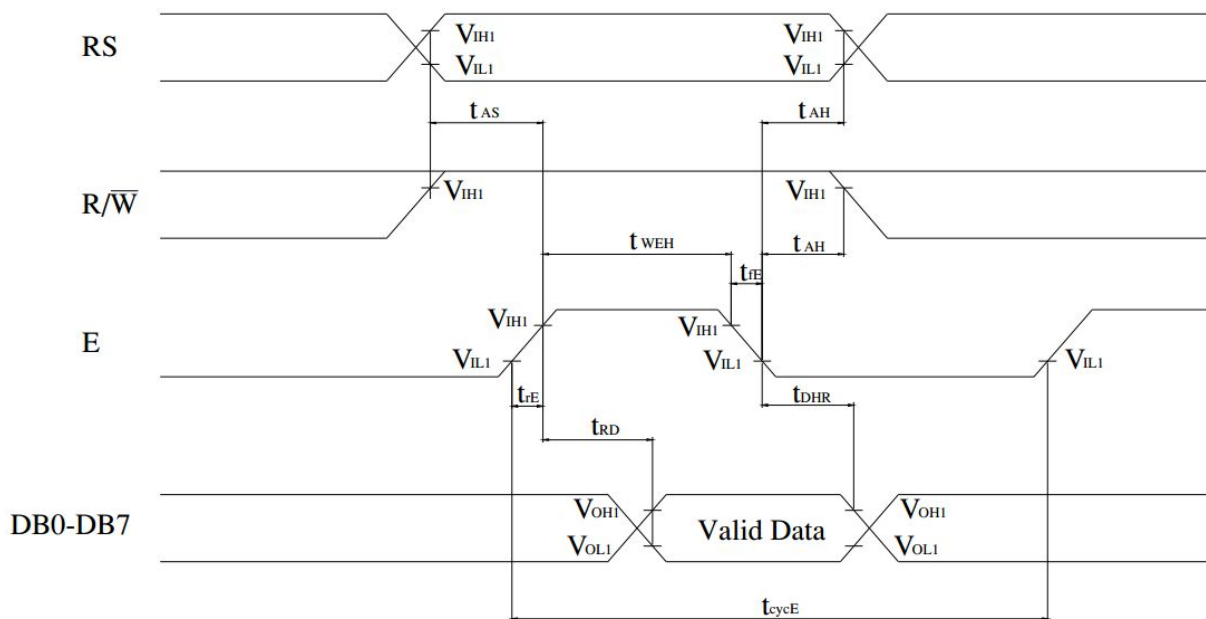

• Read cycle

VDD=5.0V±10%, VSS=0V, Ta=25°C

Characteristics	Symbol	Condition	Min.	Typ.	Max.	Unit
Enable cycle time	t _{cycE}	-	500	-	-	ns
Enable "H" level pulse width	t _{WEH}	-	300	-	-	ns
Enable rise/fall time	t _{rE} , t _{fE}	-	-	-	25	ns
RS,R/W setup time	t _{AS}	-	60 ¹	-	-	ns
			100 ²			
RS,R/W address hold time	t _{AH}	-	10	-	-	ns
Read data output delay	t _{RD}	C _L =100pF	-	-	190	ns
Read data hold time	t _{DHR}	-	20	-	-	ns

• Write cycle

Characteristics	Symbol	Condition	Min.	Typ.	Max.	Unit
Enable cycle time	t _{cycE}	-	500	-	-	ns
Enable "H" level pulse width	t _{WEH}	-	300	-	-	ns
Enable rise/fall time	t _{rE} , t _{fE}	-	-	-	25	ns
RS,R/W setup time	t _{AS}	-	60 ¹	-	-	ns
			100 ²			
RS,R/W address hold time	t _{AH}	-	10	-	-	ns
Data setup time	t _{DS}	-	100	-	-	ns
Write data hold time	t _{DH}	-	10	-	-	ns

Notes: 1: 8-bit operation mode

2: 4-bit operation mode

9. FUNCTION SPECIFICATIONS

9.1. Basic Setting

To drive the LCD module correctly and provide normally display, please use the following setting:

- N=1, 2-line display
- F=0, 5×8 dots font
- D=1, display on

Note:

- These setting/commands should issue to the LCD module while start up.
- See the Display Commands section for details.

9.2. Resetting The LCD Module

When turning on the VDD and VSS power supply, LCD module will execute the reset routine automatically. It takes about 50ms. After the reset routine, the LCD module status will be as follow:

- N=1, 2-line display
- Display clear
- DL=1, 8-bit interface
- F=0, 5 × 8 dot character font
- D=0, Display off
- C=0, Cursor off
- B=0, Blinking off
- I/D=1, Increment by 1
- S=0, No shift

NOTE:

- Reset routine could not generate the Basic Setting

9.3. Display Memory Map

9.3.1. Display Data RAM (DDRAM)

This DDRAM is used to store the display data represented in 8-bit character codes. Below figure is the relationships between DDRAM addresses and positions on the liquid crystal display.

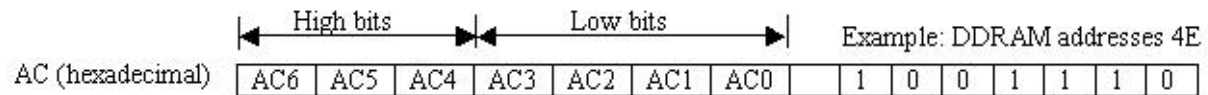

16 Chars X 2 Lines Display																
CharNo	1	2	3	4	5	6	7	8	9	10	11	12	13	14	15	16
1st Line	00	01	02	03	04	05	06	07	08	09	0A	0B	0C	0D	0E	0F
2nd Line	40	41	42	43	44	45	46	47	48	49	4A	4B	4C	4D	4E	4F

9.3.2. Character Generator RAM(CGRAM)

Character Generator RAM is for storing the User-defined Characters(5 × 8 dots font). Totally 8 User-defined Characters(character code = 00h-07h) could be created.

The User-defined Character Codes are 00h and 07h. They could be called into DDRAM as normal character.

User-defined Character Code	CGRAM Address	CGRAM Data (Font Pattern)	
		D7 ~ D5	D4 ~ D0
00h (08h)	00h 01h ⋮ 06h 07h	Not Use	5 x 8 dots font pattern
01h (09h)	08h 09h ⋮ 0Eh 0Fh	Not Use	5 x 8 dots font pattern
02h (0Ah)	10h 11h ⋮ 16h 17h	Not Use	5 x 8 dots font pattern
03h (0Bh)	18h 19h ⋮ 1Eh 1Fh	Not Use	5 x 8 dots font pattern
04h (0Ch)	20h 21h ⋮ 26h 27h	Not Use	5 x 8 dots font pattern
05h (0Dh)	28h 29h ⋮ 2Eh 2Fh	Not Use	5 x 8 dots font pattern
06h (0Eh)	30h 31h ⋮ 36h 37h	Not Use	5 x 8 dots font pattern
07h (0Fh)	38h 39h ⋮ 3Eh 3Fh	Not Use	5 x 8 dots font pattern

CGRAM Address Map

9.3.3. Character code ROM

Please refer to AIP31066 datasheet.

9.4. Display Commands

Instructions	Instruction Code										Description	Execution Time(max) ($f_{oc}=250\text{KHZ}$)	
	RS	R/W	DB7	DB6	DB5	DB4	DB3	DB2	DB1	DB0			
Clear Display	0	0	0	0	0	0	0	0	0	0	1	Clear entire display area, restore display from shift, and load address counter with DD RAM address 00H	1.64ms
Display/Cursor Home	0	0	0	0	0	0	0	0	0	1	×	Restore display from shift and load address counter with DD RAM address 00H	1.64ms
Entry Mode Set	0	0	0	0	0	0	0	1	I/D	S		Specify direction of cursor movement and display shift mode. This operation takes place after each data transfer (read/write)	40 μ s
Display ON/OFF Control	0	0	0	0	0	0	1	D	C	B		Specify activation of display (D) cursor (C) and blinking of character at cursor position (B).	40 μ s
Display/Cursor Shift	0	0	0	0	0	1	S/C	R/L	×	×		Shift display or move cursor.	40 μ s
Function Set	0	0	0	0	1	DL	N	F	×	×		Set interface data length (D), number of display line (N), and character font (F).	40 μ s
RAM Address Set	0	0	0	1	ACG							Load the address counter with a CG RAM address. Subsequent data access is for CG RAM data.	40 μ s
DD RAM Address Set	0	0	1	ADD							Load the address counter with a DD RAM address. Subsequent data access is for DD RAM data.	40 μ s	
Busy Flag/Address Counter Read	0	1	AC							Read Busy Flag (BF) and contents of Address Counter (AC).	40 μ s		
CG RAM/DD RAM Data Write	1	0	Write data							Write data to CG RAM or DD RAM.	40 μ s		
CG RAM/DD RAM Data Read	1	1	Read data							Read data from CG RAM or DD RAM	40 μ s		

NOTE:

- Do not use any other commands not listed, or the system malfunction may result.
- For the details of rte display commands, please refer to AIP31066 datasheet.

9.5. Application Circuits

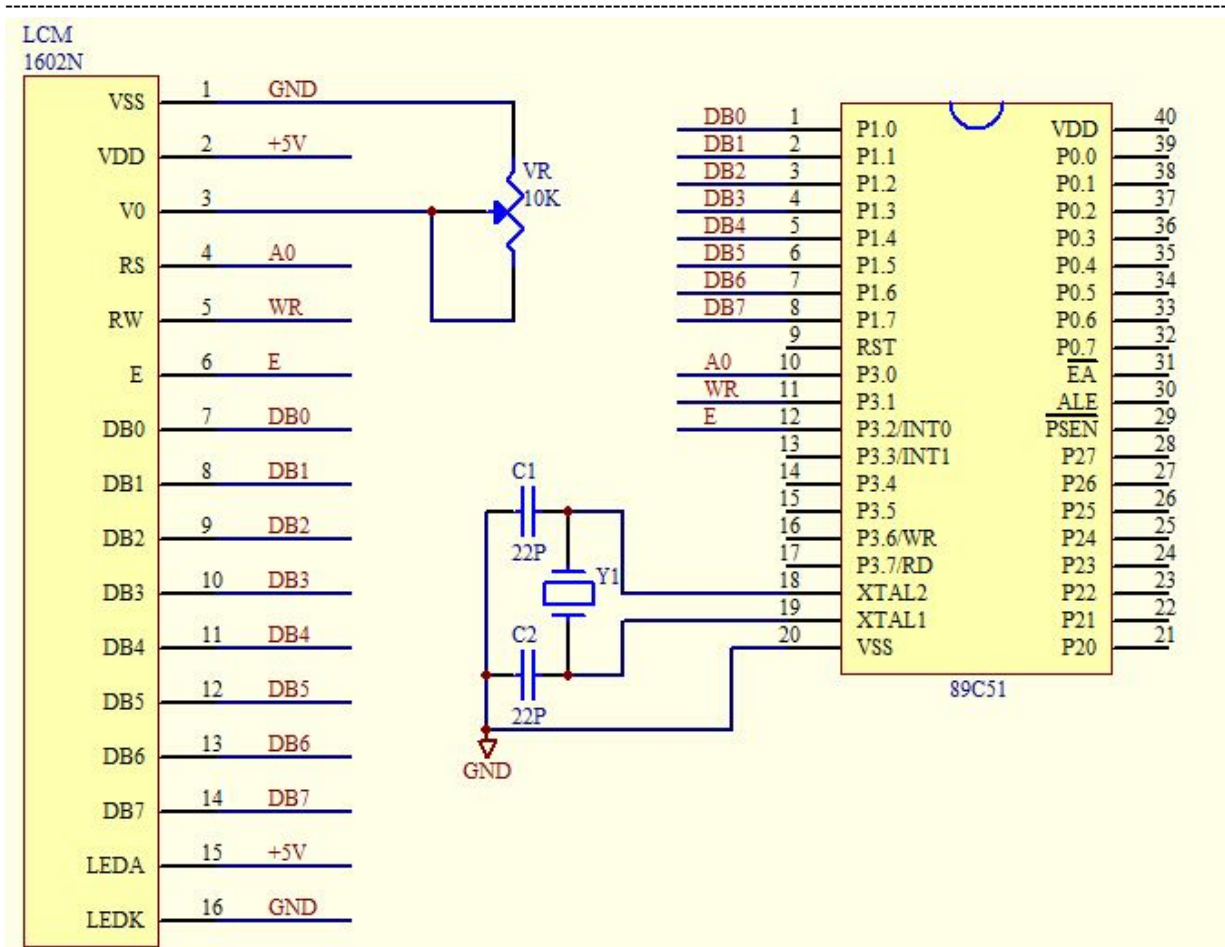

10. DESIGN AND HANDLING PRECAUTION

- 10.1. The LCD panel is made by glass. Any mechanical shock (eg. Dropping from high place) will damage the LCD module. Do not add excessive force on the surface of the display, which may cause the Display color change abnormally.
- 10.2. The polarizer on the LCD is easily get scratched. If possible, do not remove the LCD protective film until the last step of installation.
- 10.3. Never attempt to disassemble or rework the LCD module.
- 10.4. Only Clean the LCD with Isopropyl Alcohol or Ethyl Alcohol. Other solvents (eg. water) may damage the LCD.
- 10.5. When mounting the LCD module, make sure that it is free from twisting, warping and distortion.
- 10.6. Ensure to provide enough space (with cushion) between case and LCD panel to prevent external force adding on it, or it may cause damage to the LCD or degrade the display result
- 10.7. Only hold the LCD module by its side. Never hold LCD module by add force on the heat seal or TAB.
- 10.8. Never add force to component of the LCD module. It may cause invisible damage or degrade of the reliability.

-
- 10.9. LCD module could be easily damaged by static electricity. Be careful to maintain an optimum anti-static work environment to protect the LCD module.
 - 10.10. When peeling of the protective film from LCD, static charge may cause abnormal display pattern. It is normal and will resume to normal in a short while.
 - 10.11. Take care and prevent get hurt by the LCD panel edge.
 - 10.12. Never operate the LCD module exceed the absolute maximum ratings.
 - 10.13. Keep the signal line as short as possible to prevent noisy signal applying to LCD module.
 - 10.14. Never apply signal to the LCD module without power supply.
 - 10.15. IC chip (eg. TAB or COG) is sensitive to the light. Strong lighting environment could possibly cause malfunction. Light sealing structure casing is recommend.
 - 10.16. LCD module reliability may be reduced by temperature shock.
 - 10.17. When storing the LCD module, avoid exposure to the direct sunlight, high humidity, high temperature or low temperature. They may damage or degrade the LCD module