

RoHS Compliant

REV.	ECN NO.	DESCRIPTION	DATE	DESIGN

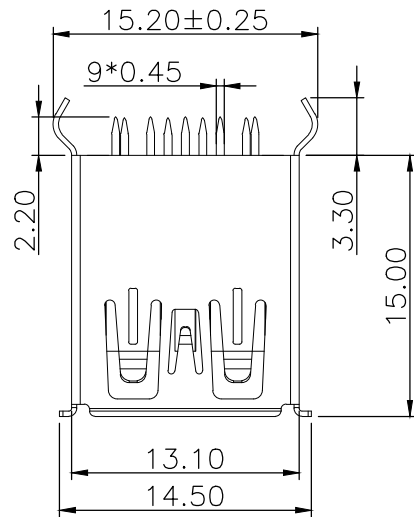

PIN NUMBER	SIGNAL NAME
PIN 1	Vbus
PIN 2	D-
PIN 3	D+
PIN 4	GND
PIN 5	StdA_SSRX-
PIN 6	StdA_SSRX+
PIN 7	GND_DRAIN
PIN 8	StdA_SSTX-
PIN 9	StdA_SSTX+
SHELL	GND

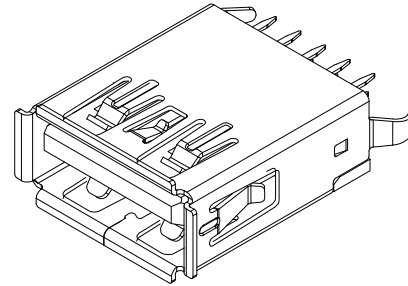

3D VIEW

NOTES:

- MATERIAL:
  - HOUSING: LCP ,COLOR IS BLUE;
  - CONTACT: BRASS(H65 T=0.20&0.25mm);
  - SHELL: BRASS(H65 T=0.30);
- ELECTRICAL:
  - VOLTAGE RATING: 30V DC ;
  - CURRENT RATING: 1.5A ;
  - CONTACT RESISTANCE: 30MILLIOHMS MAX.;
  - WITHSTAND VOLTAGE: 100V AC RMS 50(60)Hz,1MIN.;
  - INSULATION RESISTANCE: 100MEGOHMS MIN @500V DC;
- MECHANICAL:
  - MATING FORCE: 35N MAX.;
  - UNMATING FORCE: 5~35N ;
  - OPERATING LIFE: 1500 CYCLES MIN.;
- PLATING:
  - TERMINAL:
    - NI PLATING OVER ALL,
    - Tin PLATING ON SOLDER AREA,
    - Au G/Fu" ON CONTACT AREA;
  - SHELL: NI PLATING OVER ALL;
- ENVIRONMENTAL:
  - STORAGE TEMPERATURE RANGE: -40°C~+85°C;
  - OPERATION TEMPERATURE RANGE: -25°C~+70°C;

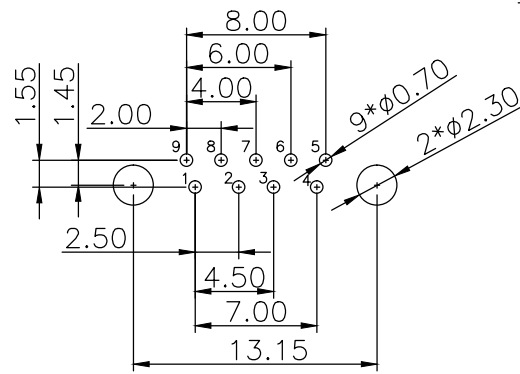
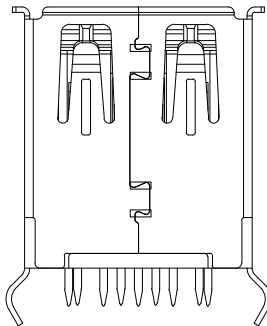
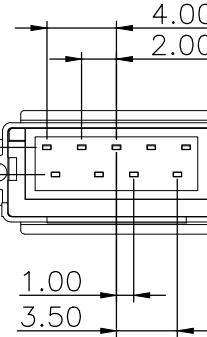
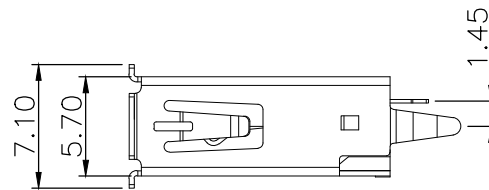
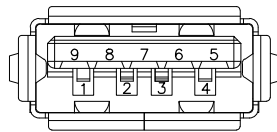

RECOMMENDER P.C.B.LAYOUT TOP VIEW  
(COMPONENT SIDE TOLERANCE±0.05)

UNLESS OTHERWISE, GENERAL TOLERANCE: X.xxx ±0.10 X.xx ±0.20 X.x ±0.30	NAME: 3.0 A母180° L15.0有边铜壳(K脚15.2)		P/N: 09.03.02.030		
	DWG NO:				
THIRD ANGLE PROJECTION 	UNIT:	SCALE:	SIZE:	SHEET:	REV.
	MM	1:1	A4	1/1	A0
DRAWN:	CHECKED:		APPROVED:		
	Y		T li		

ANGULAR:  
X.xx° ±1°  
X.x° ±3°  
X.° ±5°