

	TURNS	uH
A-C	90T	370
C-B	40T	100
A-B	90T+40T	750

COIL POSITION: CENTER

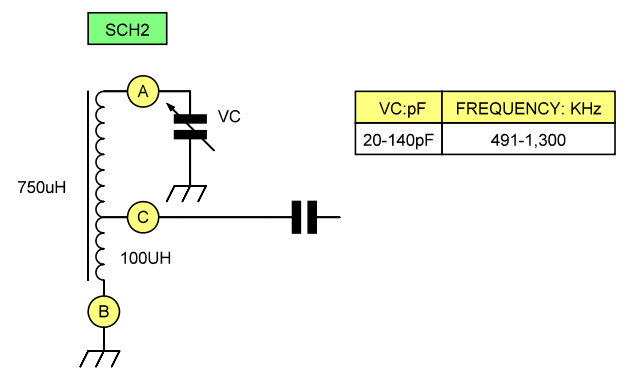
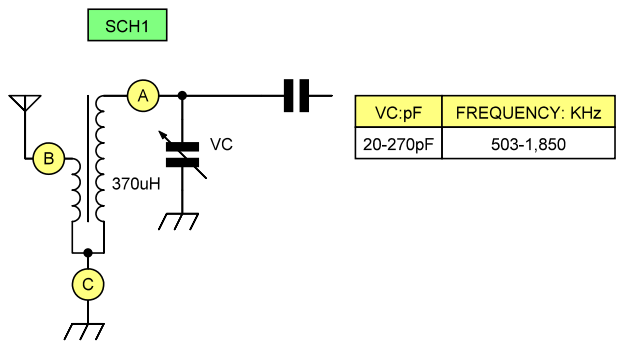
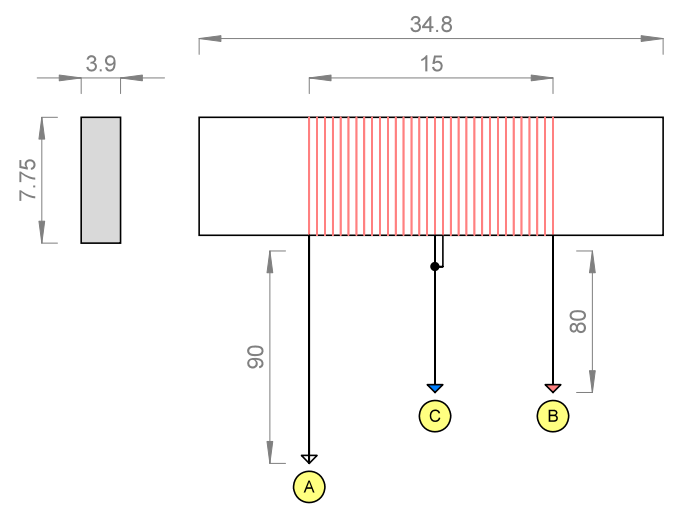

Änderungen		Datum	Name	Bezeichnung	Blatt
Datum	Name	gez.:			
		gepr.:			
		Norm:			
				Zeichnungs-Nr.:	von
				BT370C	